

AMERICAN AVK MJ to PE PIPE TRANSITION FITTINGS

MJ connection to AWWA C111/A21.11 - DIPS & IPS Polyethylene Pipe Ends
- Nominal Pipe Sizes 4" through 12"

66/80
PExMJ TRANS

Use:

For potable water, sewage, and neutral liquids to maximum 140°F under pressure.

Pressure Ratings:

Ductile iron MJ fitting rated to 250 PSI working pressure.

Pipe Stub rated to pipe manufacture's recommended working pressure based on nominal pipe size and SDR.

Standard Materials:

Fitting Ductile iron ASTM A536

Pipe PE 4710, Suitable for butt fusion or electro fusion joining. Pipe stubs to AWWA C906

Optional Materials:

Pipe SDR 9, SDR 11, SDR 13.5 DIPS or IPS. Suitable for butt fusion or electro fusion joining. Pipe stubs to AWWA C906. Specify IPS or DIPS, and SDR when placing order.

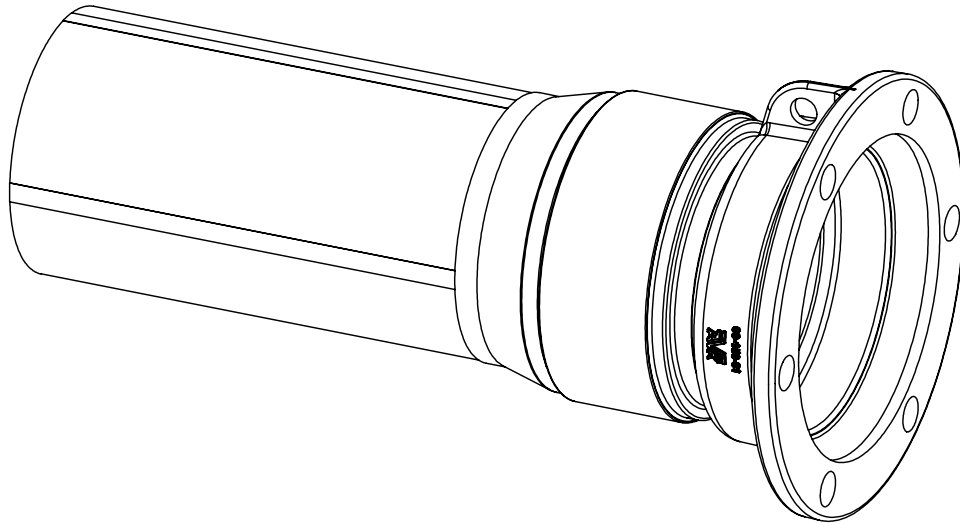

AMERICAN AVK MJ to PE PIPE TRANSITION FITTINGS

MJ connection to AWWA C111/A21.11 - DIPS & IPS Polyethylene Pipe Ends

- Nominal Pipe Sizes 4" through 12"

66/80

PExMJ TRANS

Component List:

501. MJxPE Transition Fitting

502. Pipe Stub

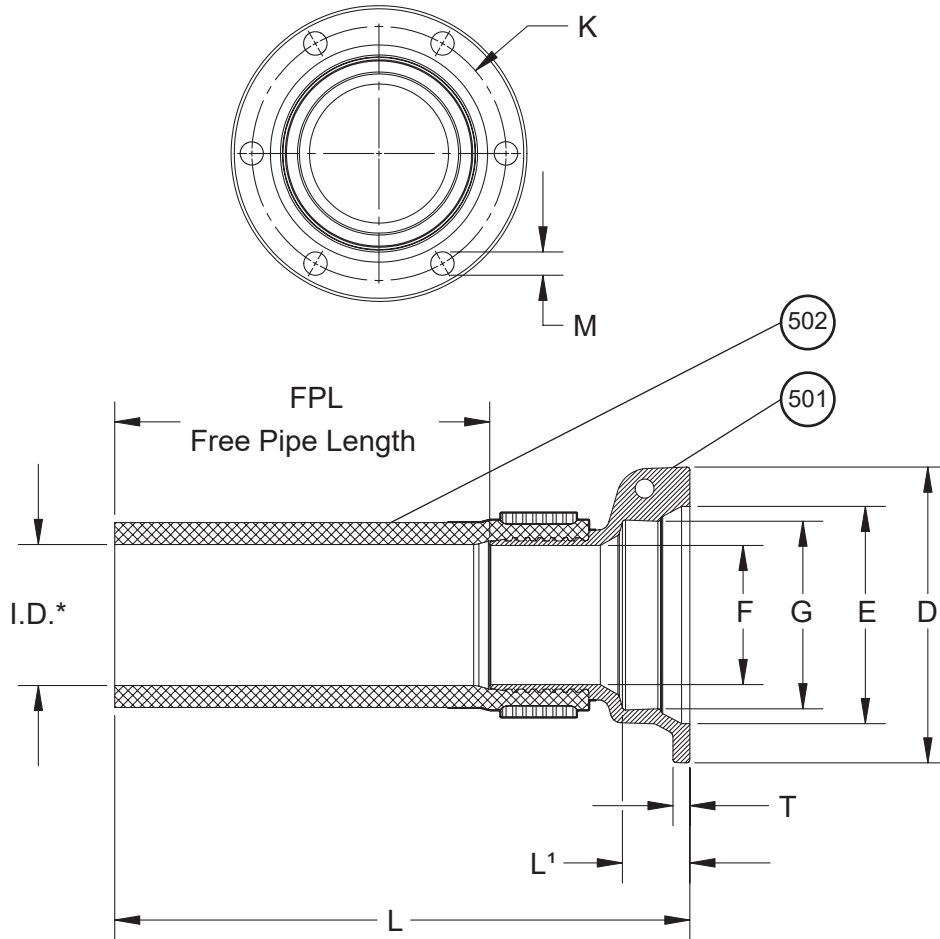

Ref. nos.	Nominal Pipe Size	B	D	F	FPL	G	K	L	M	T	Wt. Lbs.
66-100-80	4"	2.50"	9.10"	6.02"	15.20"	4.90"	7.50"	21.50"	4 - 0.88"	0.60"	27
66-150-80	6"	2.50"	11.08"	8.12"	14.30"	7.00"	9.50"	21.78"	6 - 0.88"	0.63"	42
66-200-80	8"	2.50"	13.30"	10.26"	13.26"	9.15"	11.75"	22.31"	6 - 0.88"	0.66"	65
66-250-80	10"	2.50"	15.62"	12.34"	11.54"	11.20"	14.00"	22.56"	8 - 0.88"	0.71"	112
66-300-80	12"	2.50"	17.88"	14.44"	11.43"	13.30"	16.25"	22.65"	8 - 0.88"	0.73"	152

ID*: Refer to Pipe Manufacturers reference tables

