

**AVK** SERIES 66 HDPE RESILIENT SEATED GATE VALVES

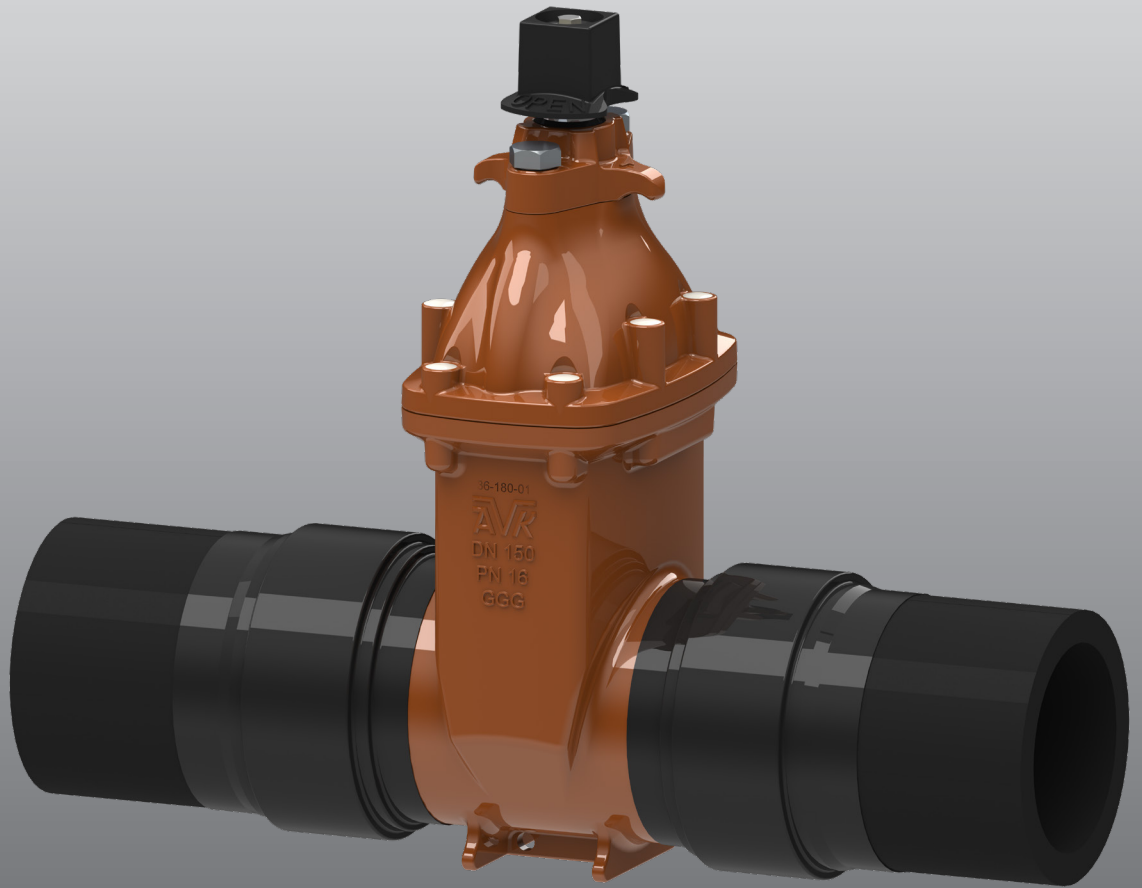

EXPECT SOLUTIONS, NOT JUST PRODUCTS



# SERIES 66 HDPE VALVES AWWA C515

## AVK STANDARD FEATURES

- AVK Series 66 Gate Valves are designed especially for use in polyethylene water distribution systems. The valve is identical to our premier resilient seated gate valve with one exception: the HDPE pipe stubs are already mounted. This means lower installation costs and leak-free joints.
- ASTM A582 stainless steel stems
- Cold-rolled threading process eliminates bent or broken stems
- Valve sizes range from 2" to 12"
- 304 stainless steel bonnet bolts are fully isolated against corrosion to eliminate bonnet bolt failures
- Certified to comply with NSF 61, NSF 372 and the new low-lead requirements of the Safe Drinking Water Act
- Series 66 Gate Valves are covered by a 10 year warranty
- Made in the USA

# RESILIENT SEATED

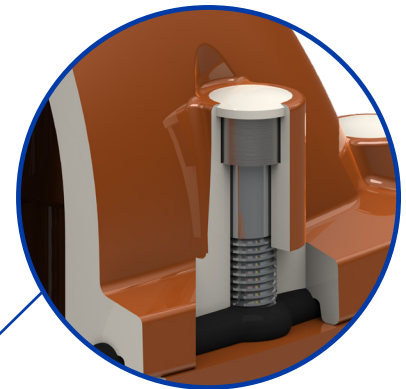

## AVK BOLTING AND GASKET SYSTEM

- 304 stainless steel bolts
- Fully isolated and protected against corrosion – bonnet bolts never come in contact with water or soil
- Countersunk and capped with hot-melt
- Easily disassembled after years of service – but, you'll never need to...

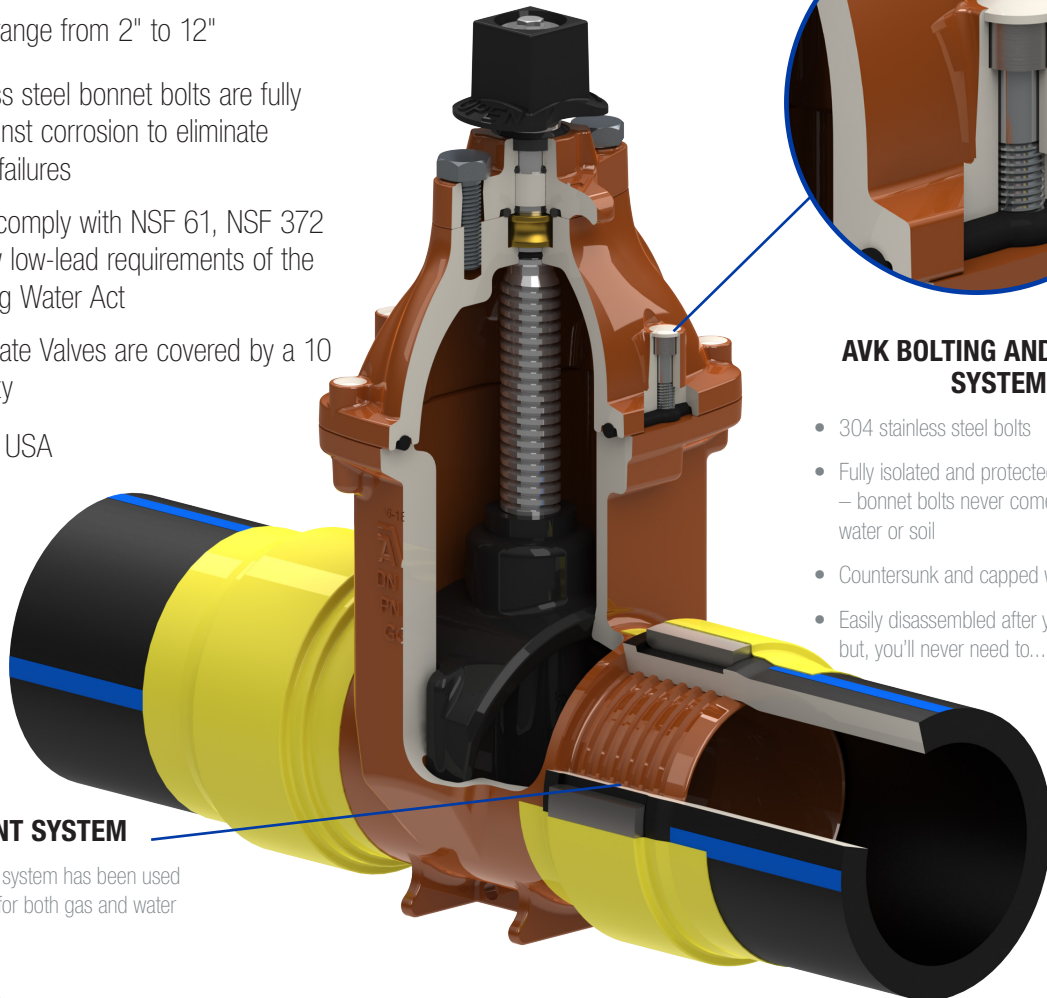

## PATENTED JOINT SYSTEM

- The AVK patented joint system has been used and proven worldwide for both gas and water installations

## American AVK Company

2155 Meridian Blvd.  
Minden, NV  
89423  
USA

Tel.: 775-552-1400  
Fax.: 775-552-1031  
sales@avkus.com  
www.americanavk.com

S-66-HDPE-Valves-F99029-04-22-2024  
Copyright©AVK Group A/S 2024