

**AMERICAN AVK RESILIENT SEATED DUCTILE IRON GATE VALVE**  
**250 PSI, Tested to AWWA C509 / C515 (NRS) for Indicator Post**  
**Push-on Joint End x Push-on Joint End (TYTON®) - Valve sizes 4" - 12" and 16"**

**45/PPP-UL**  
**POxPO PIV**

**Use:**

For water and neutral liquids to maximum 160°F.

**Tests:**

Hydraulic test to AWWA C509 & UL 262:

Shell Test: 500 PSI 4"-16"

Seat Test: 375 PSI 4"-12" - 300 PSI -16"

Operating Torque Test

**Optional Materials:**

Stem For UL, FM, ULC for 4" - 12"  
 Low Zinc Bronze ASTM B763

For UL, FM, ULC for 16"  
 Aluminum Bronze ASTM B150/B150M

Anti Friction Washers Polyamide

Wedge Ductile iron ASTM A536  
 encapsulated with NBR-rubber  
 compound

**Standard Materials:**

Body, Bonnet, Ductile iron ASTM A536  
 Post Indicator Plate, (Wrench Nut-painted black for  
 Wrench Nut open left, red for open right)

Coating Electrostatically applied fusion-  
 bonded epoxy-resin  
 Meets or exceeds AWWA C550

Stem Standard: Stainless steel - 304

Wedge Ductile iron ASTM A536  
 encapsulated with EPDM-rubber  
 compound

Wedge Nut, Thrust Collar Bronze

Bonnet Bolts Stainless Steel - 316 sealed with  
 hot melt

Gland Bolts Stainless Steel - 316  
 Hexagon bolt

Bonnet Gasket, ASTM D2000 Buna "N" nitrile  
 Wiper Ring, rubber  
 O-Ring Stem Seals,  
 O-Ring Gland Seal

**Approvals:**



\*UL/ULC Listed  
 \*FM Approved  
 Certified to: ANSI/NSF 61, ANSI/NSF 372

\* Approved at 250 PSI working pressure, 4"-12"  
 \* Approved at 200 PSI working pressure, 16"

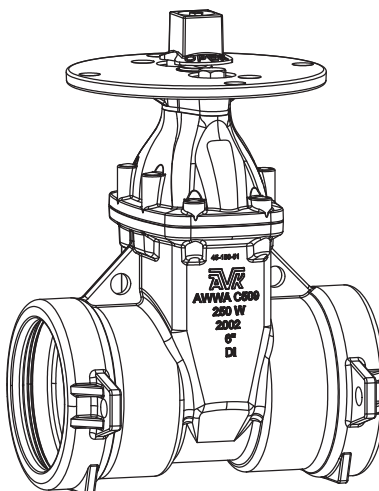

**AMERICAN AVK RESILIENT SEATED DUCTILE IRON GATE VALVE**  
**250 PSI, Tested to AWWA C509 / C515 (NRS) for Indicator Post**  
**Push-on Joint End x Push-on Joint End (TYTON®) - Valve sizes 4" - 12" and 16"**

**45/PPP-UL**  
**POxPO PIV**

Component List:

- |                           |                              |                             |
|---------------------------|------------------------------|-----------------------------|
| 217. Bonnet               | 226. Wiper Ring              | 232. Lower Stem Seal O-Ring |
| 218. Bonnet Gasket        | 227. Gland Flange Bolt       | 233. NRS Stem               |
| 219. Body                 | 229. Gland O-Ring            | 234. Thrust Collar          |
| 224. Post Indicator Plate | 230. Upper Stem Seal O-Rings | 237. Wedge                  |
| 225. Wrench Nut           | 231. Stem Seal Bushing       |                             |

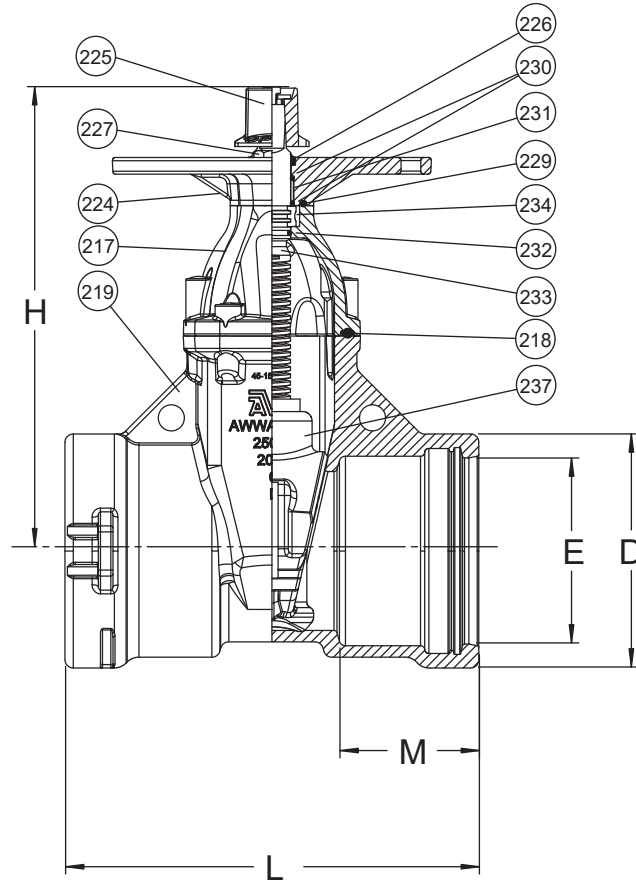

Ref No.	Size	D	E	H	L	M	Turns to Open	Weight (lbs.)
45-100-PPP-UL	4"	6.66"	4.93"	13.50"	11.99"	4.12"	14	73
45-150-PPP-UL	6"	8.84"	7.03"	17.50"	15.63"	5.22"	21	113
45-200-PPP-UL	8"	11.23"	9.18"	21.50"	17.17"	5.63"	26	170
45-250-PPP-UL	10"	13.50"	11.22"	24.75"	17.64"	5.63"	32	240
45-300-PPP-UL	12"	15.74"	13.32"	27.75"	19.21"	5.63"	38	407
45-400-PPP-UL	16"	20.62"	17.50"	34.75"	22.72"	6.00"	54	998

