

AMERICAN AVK RESILIENT SEATED DUCTILE IRON GATE VALVE
Tested to AWWA C509 / C515 (NRS) for Indicator Post
Mechanical Joint Ends - Valve Sizes 4" - 16"

45/MMP-UL
MJxMJ PIV

Use:
 For water and neutral liquids to maximum 160°F.

Tests:
 Hydraulic test to AWWA C509 & UL 262:
 Shell Test: 500 PSI 4"-16"
 Seat Test: 375 PSI 4"-12" - 300 PSI 14"-16"
 Operating Torque Test

Optional Materials:

Stem For UL, FM, ULC for 4" - 12"
 Low Zinc Bronze ASTM B763

For UL, FM, ULC for 14" - 16"
 Aluminum Bronze ASTM B150/B150M

Anti Friction Washers Polyamide

Wedge Ductile iron ASTM A536
 encapsulated with NBR-rubber
 compound

Standard Materials:

Body, Bonnet, Post Indicator Plate, Wrench Nut Ductile iron ASTM A536
 (Wrench Nut-painted black for open left, red for open right)

Coating Electrostatically applied fusion-bonded epoxy-resin
 Meets or exceeds AWWA C550

Stem Standard: Stainless steel - 304

Wedge Ductile iron ASTM A536
 encapsulated with EPDM-rubber
 compound





Wedge Nut, Thrust Collar Bronze

Bonnet Bolts Stainless Steel - 316 sealed with hot melt

Gland Bolts Stainless Steel - 316
 Hexagon bolt

Bonnet Gasket, Wiper Ring, O-Ring Stem Seals, O-Ring Gland Seal ASTM D2000 Buna "N" nitrile rubber

Approvals:

*UL/ULC Listed
 *FM Approved
 Certified to: ANSI/NSF 61, ANSI/NSF 372

* Approved at 250 PSI working pressure, 4"-12"
 * Approved at 200 PSI working pressure, 14"-16"

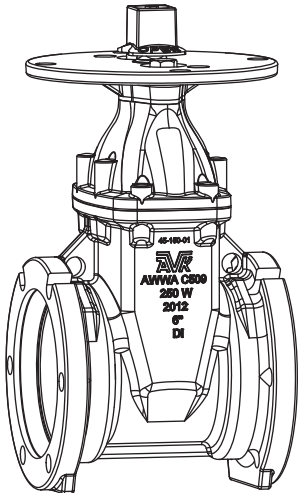

AMERICAN AVK RESILIENT SEATED DUCTILE IRON GATE VALVE
Tested to AWWA C509 / C515 (NRS) for Indicator Post
Mechanical Joint Ends - Valve Sizes 4" - 16"

45/MMP-UL
MJxMJ PIV

Component List:

- | | | |
|---------------------------|------------------------------|-----------------------------|
| 217. Bonnet | 226. Wiper Ring | 232. Lower Stem Seal O-Ring |
| 218. Bonnet Gasket | 227. Gland Flange Bolt | 233. NRS Stem |
| 219. Body | 229. Gland O-Ring | 234. Thrust Collar |
| 224. Post Indicator Plate | 230. Upper Stem Seal O-Rings | 237. Wedge |
| 225. Wrench Nut | 231. Stem Seal Bushing | |

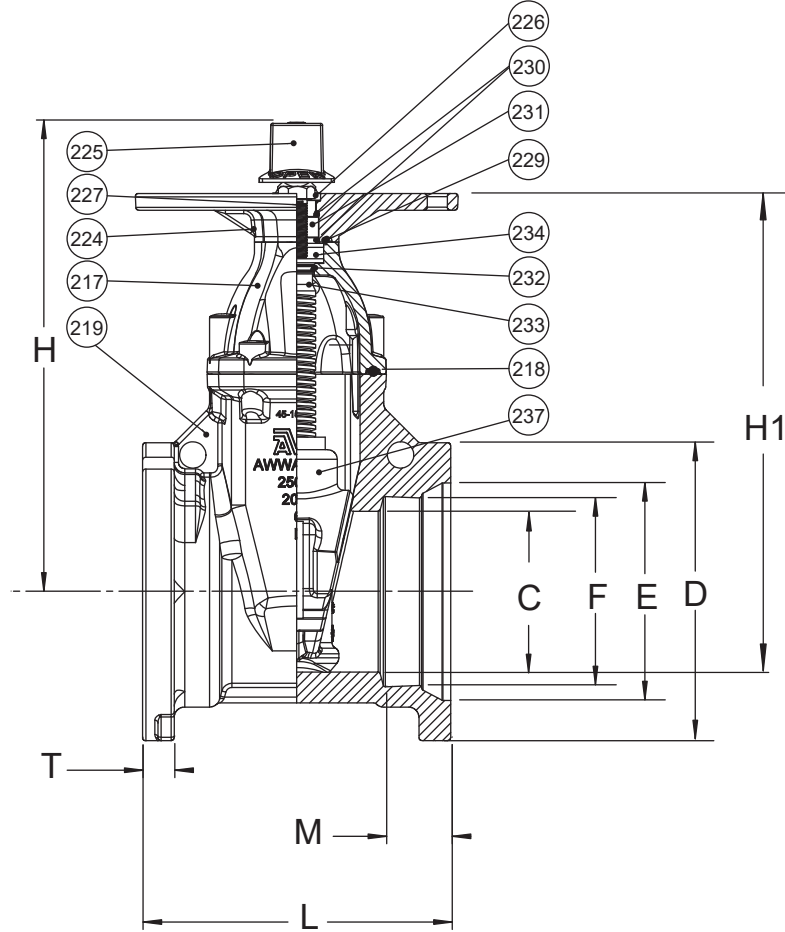

Ref No.	Size	C	D	E	F	H	H1	L	M	T	Turns to Open	Weight (lbs.)
45-100-MMP-UL	4"	4.25"	9.12"	6.00"	4.90"	13.50"	13.00"	10.00"	2.50"	1.00"	14	82
45-150-MMP-UL	6"	6.25"	11.12"	8.12"	7.00"	17.50"	18.00"	11.50"	2.50"	1.18"	21	123
45-200-MMP-UL	8"	8.25"	13.37"	10.27"	9.15"	21.50"	23.00"	11.50"	2.50"	1.24"	26	175
45-250-MMP-UL	10"	10.25"	15.69"	12.34"	11.20"	24.75"	27.00"	13.00"	2.50"	1.14"	32	260
45-300-MMP-UL	12"	12.25"	17.88"	14.44"	13.30"	27.63"	31.00"	14.00"	2.50"	1.22"	38	357
45-350-MMP-UL	14"	14.00"	20.31"	16.61"	15.50"	35.38"	39.00"	17.95"	3.50"	1.32"	51	814
45-400-MMP-UL	16"	16.00"	22.56"	18.64"	17.54"	35.47"	42.00"	18.00"	3.50"	1.34"	54	820

