

**AMERICAN AVK RESILIENT SEATED DUCTILE IRON GATE VALVE**  
**Tested to AWWA C509 / C515 (NRS) for Indicator Post**  
**Flanged Ends to ASME B16.42 Class 150 - Valve sizes 4" - 16"**

**45/FFP-UL  
 FLxFL PIV**

**Use:**

For water and neutral liquids to maximum 160°F.

**Tests:**

Hydraulic test to AWWA C509 & UL 262:

Shell Test: 500 PSI 4"-16"

Seat Test: 375 PSI 4"-12" - 300 PSI 14"-16"

Operating Torque Test

**Optional Materials:**

Stem For UL, FM, ULC for 4" - 12"  
 Low Zinc Bronze ASTM B763

For UL, FM, ULC for 14" - 16"  
 Aluminum Bronze ASTM B150/B150M

Anti Friction Washers Polyamide

Wedge Ductile iron ASTM A536  
 encapsulated with NBR-rubber  
 compound

Standard Materials:  
 Body, Bonnet,  
 Post Indicator Plate,  
 Wrench Nut

Ductile iron ASTM A536  
 (Wrench Nut-painted black for  
 open left, red for open right)

Coating

Electrostatically applied fusion-  
 bonded epoxy-resin  
 Meets or exceeds AWWA C550

Stem

Stainless steel 304, 4"-12"  
 Aluminum Bronze C63020, 14"-16"

Wedge

Ductile iron ASTM A536  
 encapsulated with EPDM-rubber  
 compound

Wedge Nut, Thrust Collar Bronze

Bonnet Bolts Stainless Steel - 316  
 sealed with hot melt

Gland Bolts Stainless Steel - 316  
 Hexagon bolt

Bonnet Gasket,  
 Wiper Ring,  
 O-Ring Stem Seals,  
 O-Ring Gland Seal  
 ASTM D2000 Buna "N" nitrile  
 rubber

**Approvals:**



\*UL/ULC Listed  
 \*FM Approved  
 Certified to: ANSI/NSF 61, ANSI/NSF 372

\* Approved at 250 PSI working pressure, 4"-12"  
 \* Approved at 200 PSI working pressure, 14"-16"

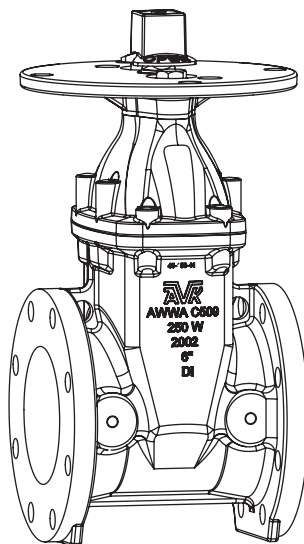

**AMERICAN AVK RESILIENT SEATED DUCTILE IRON GATE VALVE**  
**Tested to AWWA C509 / C515 (NRS) for Indicator Post**  
**Flanged Ends to ASME B16.42 Class 150 - Valve sizes 4" - 16"**

**45/FFP-UL**  
**FLxFL PIV**

Component List:

- |                           |                              |                             |
|---------------------------|------------------------------|-----------------------------|
| 217. Bonnet               | 226. Wiper Ring              | 232. Lower Stem Seal O-Ring |
| 218. Bonnet Gasket        | 227. Gland Flange Bolt       | 233. NRS Stem               |
| 219. Body                 | 229. Gland O-Ring            | 234. Thrust Collar          |
| 224. Post Indicator Plate | 230. Upper Stem Seal O-Rings | 237. Wedge                  |
| 225. Wrench Nut           | 231. Stem Seal Bushing       |                             |

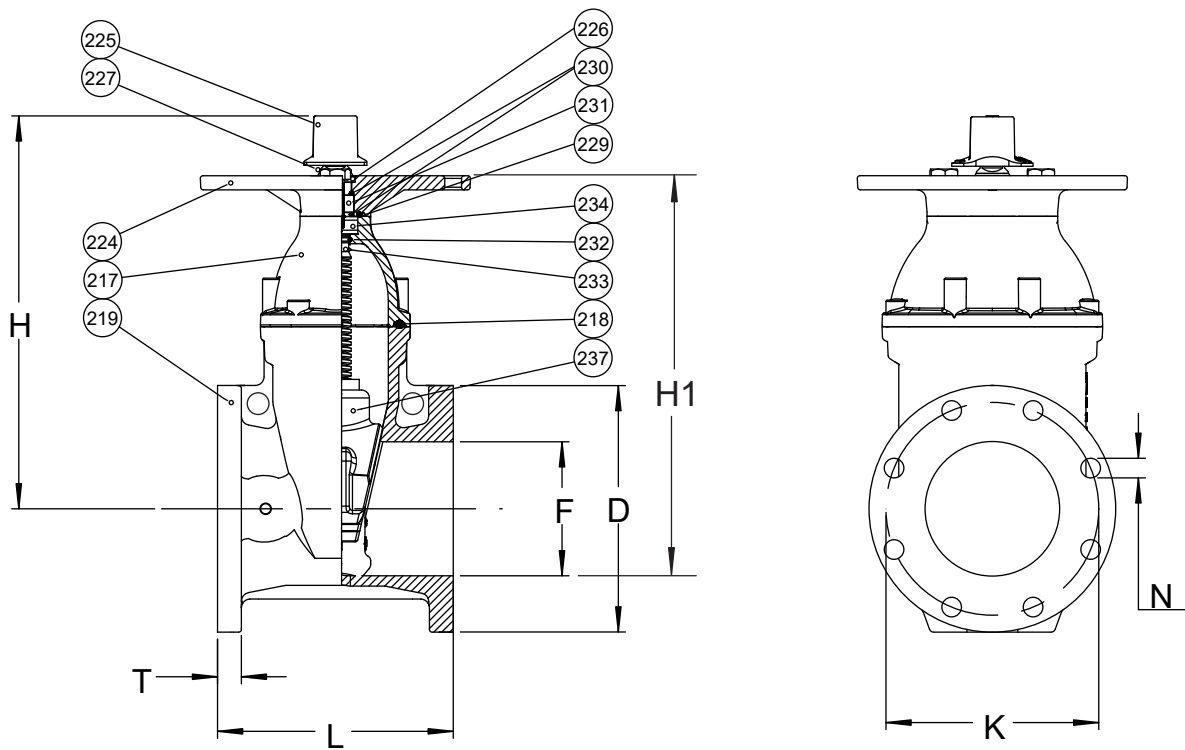

Ref No.	Size	D	F	H	H1	K	L	N	T	Flange Holes	Turns to Open	Weight (lbs.)
45-100-FFP-UL	4"	9.00"	4.00"	13.50"	13.00"	7.50"	9.00"	0.75"	1.00"	8	14	78
45-150-FFP-UL	6"	11.00"	6.00"	17.50"	18.00"	9.50"	10.50"	0.88"	1.06"	8	21	112
45-200-FFP-UL	8"	13.50"	8.00"	21.50"	23.00"	11.75"	11.50"	0.88"	1.14"	8	26	169
45-250-FFP-UL	10"	16.00"	10.00"	24.75"	27.00"	14.25"	13.00"	1.00"	1.22"	12	32	284
45-300-FFP-UL	12"	19.00"	12.00"	27.63"	31.00"	17.00"	14.00"	1.00"	1.30"	12	38	424
45-350-FFP-UL	14"	20.98"	14.00"	35.75"	39.00"	18.75"	15.00"	1.13"	1.40"	12	51	635
45-400-FFP-UL	16"	23.50"	16.00"	34.74"	42.00"	21.25"	16.00"	1.13"	1.44"	16	54	805

