

**AMERICAN AVK RESILIENT SEATED DUCTILE IRON GATE VALVE**  
**250/350 PSI, Tested to AWWA C509 / C515 (NRS)**  
**Flanged Ends to ASME B16.42 Class 150 - Valve sizes 2.5" - 16"**

**45/FFN-WD**  
**FLxFL**

**Use:**

For water and neutral liquids to maximum 160°F.

**Tests:**

Hydraulic test to AWWA C509:

Shell Test: 700 PSI 2.5"-12"

Seat Test: 350 PSI 2.5"-12"

Shell Test: 500 PSI 14"-16"

Seat Test: 250 PSI 14"-16"

Operating Torque Test

**Optional Materials:**

Wedge                      Ductile iron ASTM A536  
 encapsulated with NBR-rubber  
 compound

Stem                        304 stainless steel

Handwheel                Cast Iron ASTM A126 class B

**Standard Materials:**

Body, Bonnet,  
 Gland Flange,  
 Wrench Nut                Ductile iron ASTM A536  
 (Wrench Nut-painted black for  
 open left, red for open right)

Coating                    Electrostatically applied fusion-  
 bonded epoxy-resin  
 Meets or exceeds AWWA C550

Stem                        Standard: Stainless steel 430F

Wedge                     Ductile iron ASTM A536  
 encapsulated with EPDM-rubber  
 compound

Wedge Nut, Thrust Collar    Bronze

Bonnet Bolts                Stainless Steel - 316 sealed with  
 hot melt

Gland Bolts                Stainless Steel - 316  
 Hexagon bolt

Bonnet Gasket,  
 Wiper Ring,  
 O-Ring Stem Seals,  
 O-Ring Gland Seal        ASTM D2000 Buna "N" nitrile  
 rubber

**Approvals:**

Certified to: ANSI/NSF 61, ANSI/NSF 372

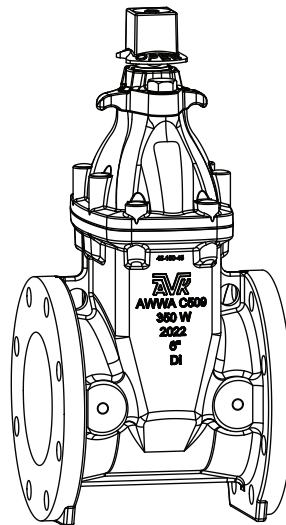

**AMERICAN AVK RESILIENT SEATED DUCTILE IRON GATE VALVE**  
**250/350 PSI, Tested to AWWA C509 / C515 (NRS)**  
**Flanged Ends to ASME B 16.42 Class 150 - Valve sizes 2.5" - 16"**

**45/FFN-WD**  
**FLxFL**

Component List:

- |                    |                              |                             |
|--------------------|------------------------------|-----------------------------|
| 217. Bonnet        | 227. Gland Flange Bolt       | 232. Lower Stem Seal O-Ring |
| 218. Bonnet Gasket | 228. Gland Flange            | 233. NRS Stem               |
| 219. Body          | 229. Gland O-Ring            | 234. Thrust Collar          |
| 225. Wrench Nut    | 230. Upper Stem Seal O-Rings | 237. Wedge                  |
| 226. Wiper Ring    | 231. Stem Seal Bushing       |                             |

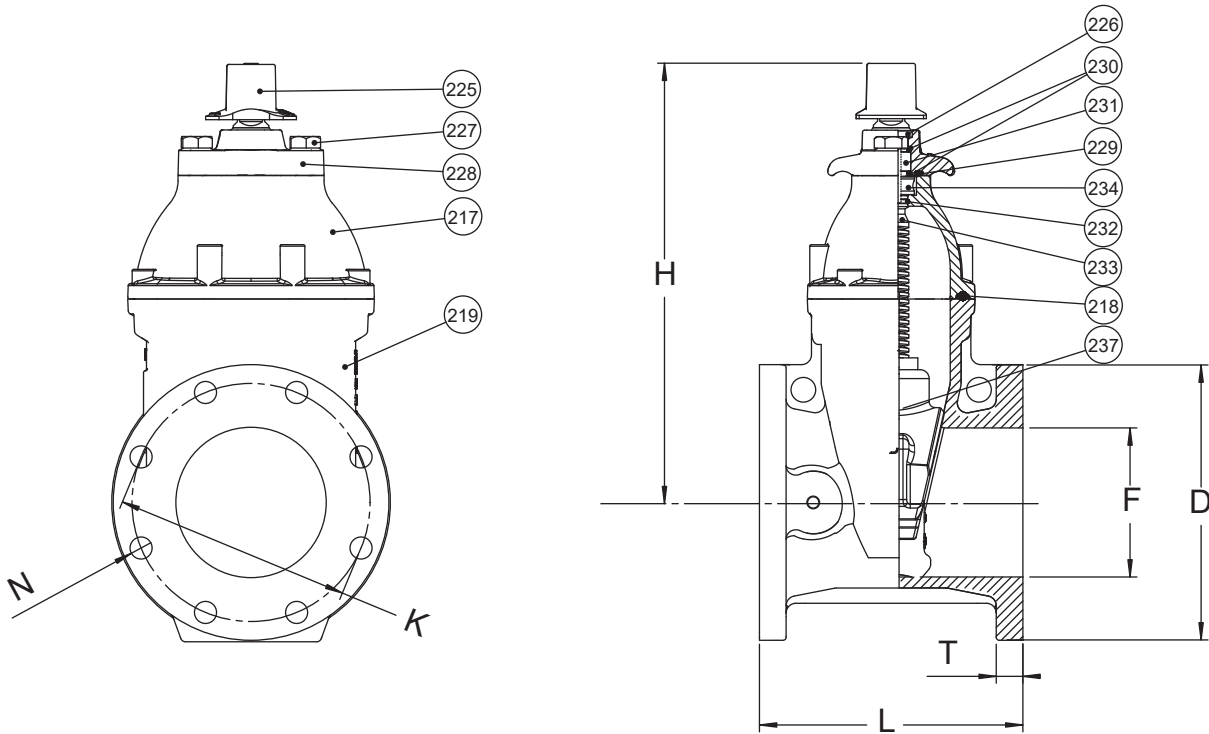

Ref No.	Size	Working Pressure	D	F	H	K	L	N	T	Flange Holes	Turns to Open	Weight (lbs.)
45-065-FFN-WD	2.5"	350	7.00"	2.50"	12.09"	5.50"	7.50"	0.75"	0.71"	4	12	38
45-080-FFN-WD	3"	350	7.50"	3.00"	12.09"	6.00"	8.00"	0.75"	0.79"	4	12	42
45-100-FFN-WD	4"	350	9.00"	4.00"	13.50"	7.50"	9.00"	0.75"	1.00"	8	14	63
45-150-FFN-WD	6"	350	11.00"	6.00"	17.50"	9.50"	10.50"	0.88"	1.06"	8	20	97
45-200-FFN-WD	8"	350	13.50"	8.00"	21.50"	11.75"	11.50"	0.88"	1.14"	8	26	154
45-250-FFN-WD	10"	350	16.00"	10.00"	24.75"	14.25"	13.00"	1.00"	1.22"	12	32	269
45-300-FFN-WD	12"	350	19.00"	12.00"	27.63"	17.00"	14.00"	1.00"	1.30"	12	38	409
45-350-FFN-WD	14"	250	20.98"	14.00"	35.75"	18.75"	15.00"	1.13"	1.18"	12	51	620
45-400-FFN-WD	16"	250	23.50"	16.00"	34.74"	21.25"	16.00"	1.13"	1.44"	16	54	790

