

AVK CONCENTRIC BUTTERFLY VALVE WITH VULCANIZED LINER, CLASS 250B - ABOVE GROUND

816/BFV/ROT/GB
MJxFL

Mechanical Joint & Flanged Ends to ANSI B16.42 class 150 - Valve Sizes 6" - 24"

Use:

For water to maximum 160°F.

Tests:

Hydraulic tests to AWWA C504:

250B

Shell Test: 500 PSI

Seat Test: 250 PSI

Standard Materials:

Body	Ductile iron ASTM A536 with vulcanized EPDM liner
Coating	Two Component, High Solids Epoxy
Stems	Standard: 17-4PH Stainless steel ASTM A564
Bushings	Copper alloy ASTM B505
Disc	Ductile iron ASTM A536 with Ni-Cu seat
Mounting hardware, Set Screw	Stainless steel
O-rings	ASTM D2000 Buna "N" nitrile rubber

Approvals:

Certified to: ANSI/NSF 61, ANSI/NSF 372

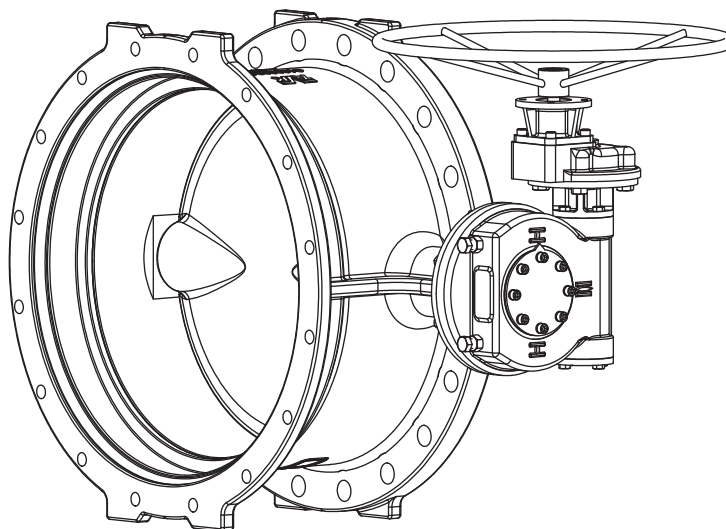

AVK CONCENTRIC BUTTERFLY VALVE

WITH VULCANIZED LINER, CLASS 150B&250B - ABOVE GROUND

Mechanical Joint & Flanged Ends to ANSI B16.42 class 150 - Valve Sizes 6" - 24"

816/BFV/ROT/GB

MJxFL

Component List:

- | | | | |
|-------------------------|----------------------------------|---------------------------------|------------------------|
| 801. Body | 811. Gearbox | 818. Stem Plate | 825. End Plate |
| 804. Upper Shaft O-ring | 812. Hand Wheel | 819. O-ring Retainer | 826. End Plate Washers |
| 805. Drive Shaft | 814. Gearbox Bolt | 820. Stem-Disc Screws | 827. End Plate Bolts |
| 806. Stub Shaft | 815. Gearbox Washer | 821. Axial Bearing | 828. Stem Plug O-ring |
| 807. Disc | 816. Hand Wheel Set Screw* | 822. Bearing Adjustment Screws* | 829. Stem Plug |
| 810. Gearbox Key* | 817. Stem Plate Retaining Screws | 824. End Plate O-ring | |

* Not shown

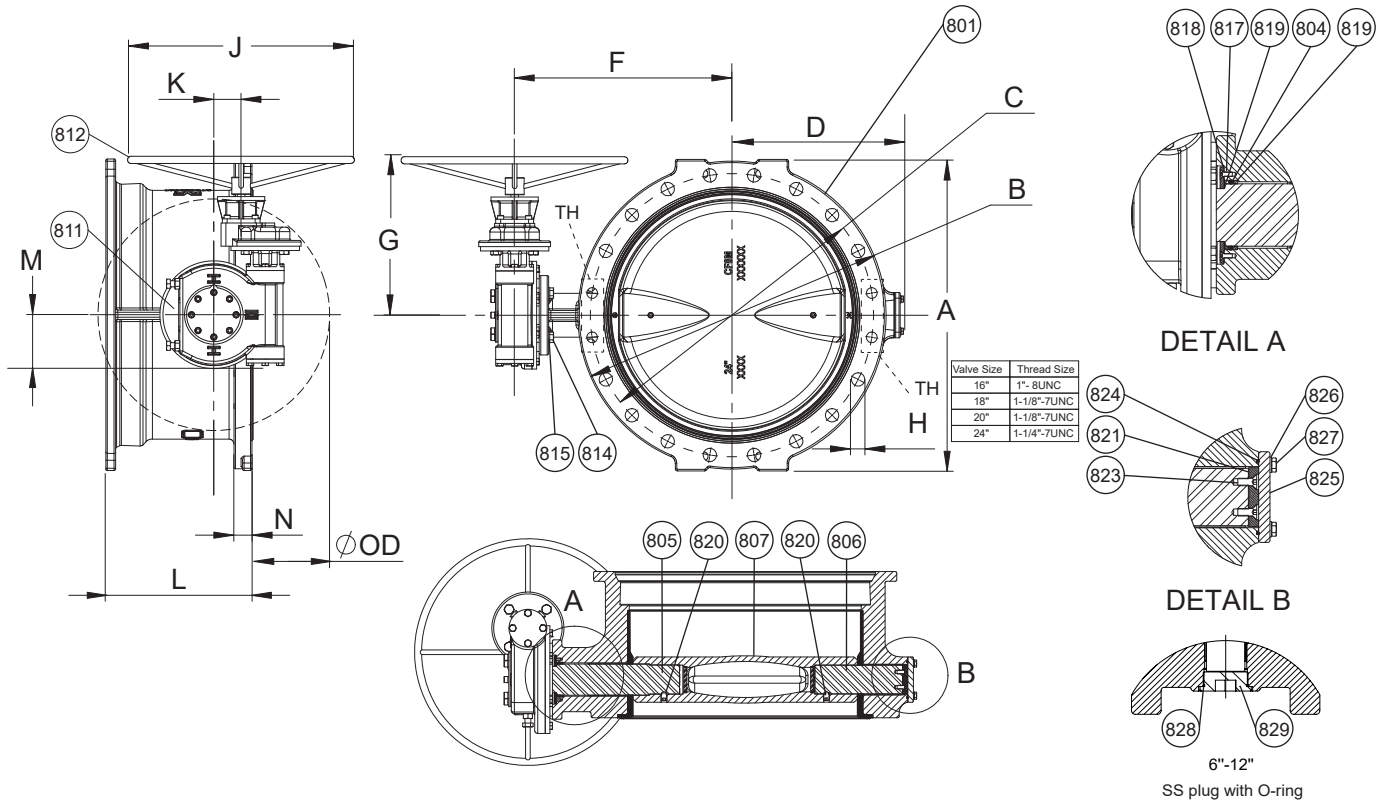

Ref No.	Size	MJ/FL											ØOD	150/250	TURNS TO OPEN			WT. LBS.
		A	B	C	D	F	G	H	J	K	L	M			N	HL/TH*	NO. OF	
816-150-MF-RGB	6"	11.45"	11.00"/11.00"	9.50"/9.50"	5.50"	8.66"	7.91"	0.88"	7.87"	2.80"	6.89"	2.71"	0.63"/1.00"	0.53"	9/9	M-6/0	F-8/0	73
816-200-MF-RGB	8"	14.00"	13.30"/13.58"	11.75"/11.77"	6.75"	9.69"	10.35"	0.88"	7.87"	3.38"	8.22"	3.94"	0.66"/1.13"	1.04"	10/10	M-6/0	F-8/0	115
816-250-MF-RGB	10"	16.38"	15.69"/15.94"	14.00"/14.25"	8.00"	11.30"	10.35"	0.88"/1.00"	11.81"	3.38"	9.83"	3.94"	0.70"/1.19"	1.02"	10/10	M-8/0	F-12/0	160
816-300-MF-RGB	12"	19.53"	17.88"/19.00"	16.25"/17.00"	9.50"	12.29"	10.35"	0.88"/1.00"	11.81"	3.38"	10.48"	3.94"	0.73"/1.25"	2.03"	10/10	M-8/0	F-12/0	200
816-350-MF-RGB	14"	21.50"	20.25"/21.00"	18.75"/18.75"	10.70"	14.02"	11.73"	0.88"/1.13"	15.75"	3.38"	12.10"	3.94"	0.79"/1.38"	3.03"	10/10	M-12/0	F-12/4	269
816-400-MF-RGB	16"	23.82"	22.50"/23.42"	21.00"/21.25"	12.28"	15.95"	11.73"	0.88"/1.13"	15.75"	3.38"	12.73"	3.94"	0.85"/1.44"	4.03"	10/10	M-12/0	F-12/4	360
816-450-MF-RGB	18"	25.20"	24.83"/25.00"	23.23"/22.75"	13.56"	16.94"	11.73"	0.88"/1.25"	23.62"	4.11"	13.35"	4.33"	1.00"/1.56"	5.04"	10/12	M-12/0	F-12/4	511
816-500-MF-RGB	20"	27.95"	22.91"/27.56"	25.50"/25.00"	14.70"	18.98"	16.54"	0.88"/1.25"	23.62"	5.35"	14.10"	5.35"	1.00"/1.70"	6.04"	12/24	M-14/0	F-16/4	601
816-600-MF-RGB	24"	32.44"	31.58"/32.00"	30.00"/29.48"	17.85"	22.80"	16.54"	0.88"/1.38"	23.62"	5.35"	15.23"	5.35"	1.02"/1.88"	8.05"	24/38	M-16/0	F-16/4	835

* HL/TH - Holes/Threaded per flange

F - FL, M - MJ, NA - Not Applicable

