

**AVK CONCENTRIC BUTTERFLY VALVE, ROTORK ACTUATION, 816/BFV/ROT/GB
WITH VULCANIZED LINER, CLASS 250B - ABOVE GROUND FLxFL**
Flanged Ends to ANSI B16.42 class 150 - Valve Sizes 3" - 24"

Use:
For water to maximum 160°F.

Tests:
Hydraulic tests to AWWA C504:
250B
Shell Test: 500 PSI
Seat Test: 250 PSI

Approvals:
Certified to: ANSI/NSF 61, ANSI/NSF 372



Standard Materials:

Body	Ductile iron ASTM A536 with vulcanized EPDM liner
Coating	Two Component, High Solids Epoxy
Stems	Standard: 17-4PH Stainless steel ASTM A564
Bushings	Copper alloy ASTM B505
Disc (*)	Ductile iron ASTM A536 with Ni-Cu seat
Mounting hardware, Set Screw	Stainless steel
O-rings	ASTM D2000 Buna "N" nitrile rubber

(*) 3"-4" disc material is CF8M 316 stainless steel

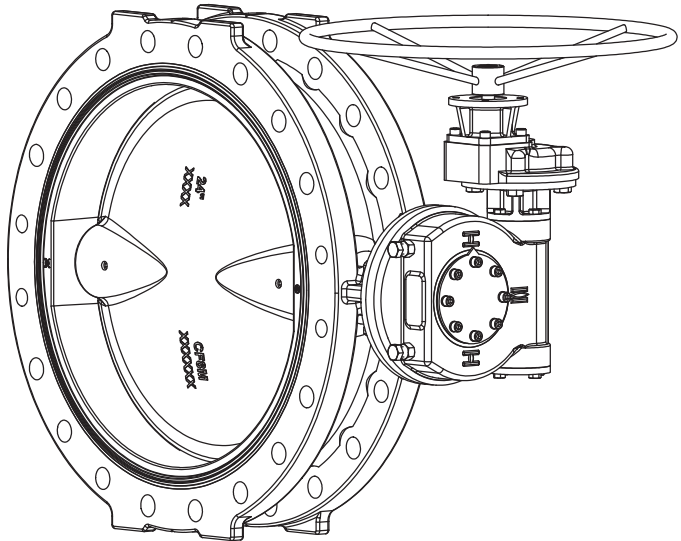

AVK CONCENTRIC BUTTERFLY VALVE, ROTORK ACTUATION, 816/BFV/ROT/GB WITH VULCANIZED LINER, CLASS 250B - ABOVE GROUND Flanged Ends to ANSI B16.42 class 150 - Valve Sizes 3" - 24"

FLxFL

Component List:

- | | | | |
|-------------------------|----------------------------------|---------------------------------|------------------------|
| 801. Body | 811. Gearbox | 818. Stem Plate | 825. End Plate |
| 804. Upper Shaft O-ring | 812. Hand Wheel | 819. O-ring Retainer | 826. End Plate Washers |
| 805. Drive Shaft | 814. Gearbox Bolt | 820. Stem-Disc Screws | 827. End Plate Bolts |
| 806. Stub Shaft | 815. Gearbox Washer | 821. Axial Bearing | 828. Stem Plug O-ring |
| 807. Disc | 816. Hand Wheel Set Screw* | 822. Bearing Adjustment Screws* | 829. Stem Plug |
| 810. Gearbox Key* | 817. Stem Plate Retaining Screws | 824. End Plate O-ring | |

* Not shown

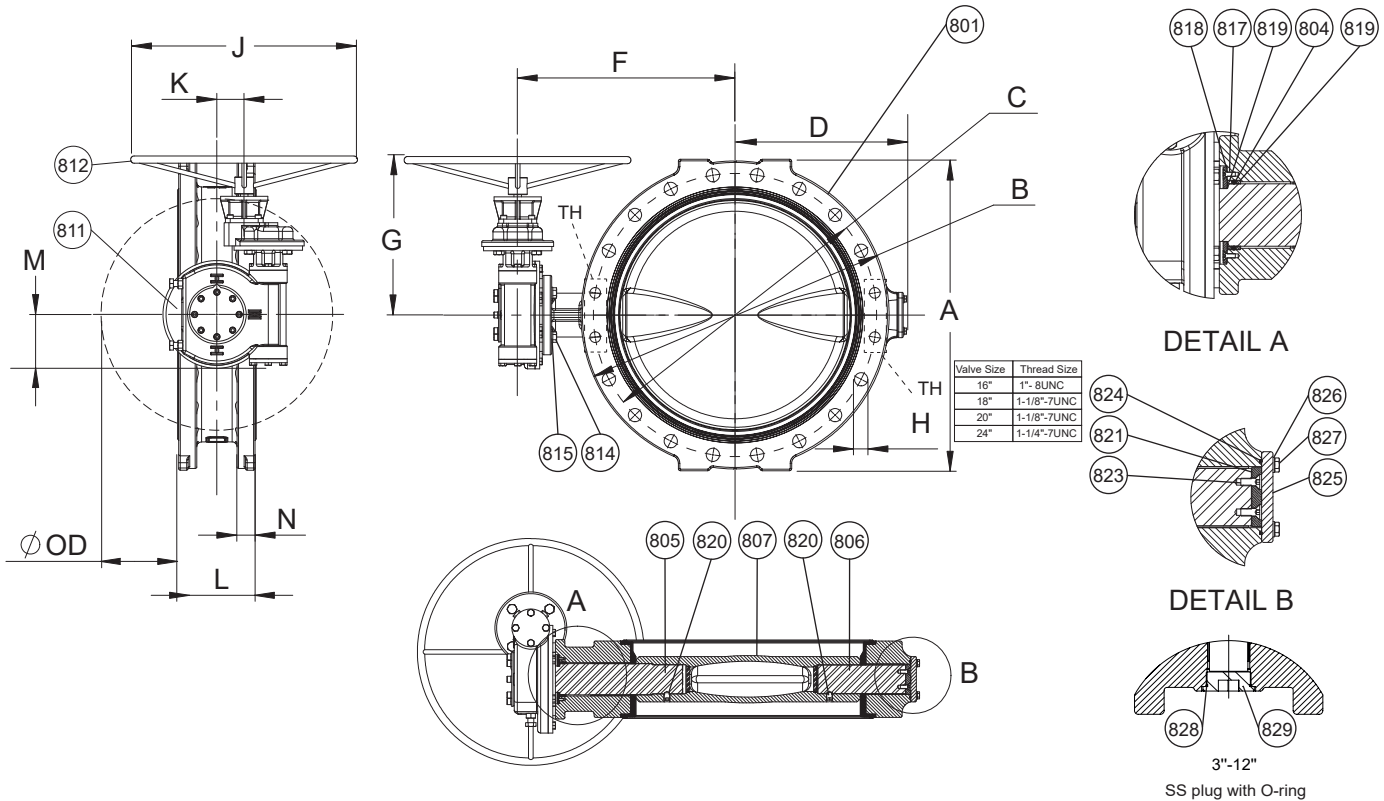

Ref No.	Size	A	B	C	D	F	G	H	J	K	L	M	N	ØOD	TURNS TO OPEN	NO. OF HL/TH*	SHPG. WT. LBS.
816-080-FF-RGB	3"	7.50"	7.50"	6.00"	3.75"	6.86"	7.91"	0.75"	7.87"	2.80"	5.00"	2.71"	0.75"	NA	9/9	4/0	45
816-100-FF-RGB	4"	9.00"	9.00"	7.50"	4.50"	7.38"	7.91"	0.75"	7.87"	2.80"	5.00"	2.71"	0.94"	NA	9/9	8/0	57
816-150-FF-RGB	6"	11.00"	11.00"	9.50"	5.50"	8.66"	7.91"	0.88"	7.87"	2.80"	5.00"	2.71"	1.00"	0.53"	9/9	8/0	72
816-200-FF-RGB	8"	13.50"	13.50"	11.75"	6.75"	9.69"	10.35"	0.88"	7.87"	3.38"	6.00"	3.94"	1.13"	1.04"	10/10	8/0	118
816-250-FF-RGB	10"	16.00"	16.00"	14.25"	8.00"	11.30"	10.35"	1.00"	11.81"	3.38"	8.00"	3.94"	1.19"	1.02"	10/10	12/0	165
816-300-FF-RGB	12"	19.00"	19.00"	17.00"	9.50"	12.29"	10.35"	1.00"	11.81"	3.38"	8.00"	3.94"	1.25"	2.03"	10/10	12/0	215
816-350-FF-RGB	14"	21.50"	21.00"	18.75"	10.70"	14.02"	11.73"	1.13"	15.75"	3.38"	8.00"	3.94"	1.38"	3.03"	10/10	12/0	270
816-400-FF-RGB	16"	23.82"	23.50"	21.25"	12.28"	15.95"	11.73"	1.13"	15.75"	3.38"	8.00"	3.94"	1.44"	4.03"	10/10	12/4	354
816-450-FF-RGB	18"	25.39"	25.00"	22.75"	13.56"	16.94"	11.73"	1.25"	23.62"	4.11"	8.00"	4.33"	1.56"	5.04"	10/12	12/4	488
816-500-FF-RGB	20"	27.95"	27.50"	25.00"	14.70"	18.98"	16.54"	1.25"	23.62"	5.35"	8.00"	5.35"	1.70"	6.04"	12/24	16/4	573
816-600-FF-RGB	24"	32.44"	32.00"	29.50"	17.85"	22.80"	16.54"	1.38"	23.62"	5.35"	8.00"	5.35"	1.88"	8.05"	24/38	16/4	793

* HL/TH - Holes/Threaded per flange
NA - Not Applicable

