

AMERICAN AVK RESILIENT SEATED GATE VALVE
250 PSI, Tested to AWWA C515 (NRS)
Mechanical Joint Ends to AWWA C111 - Valve Size 30"

55/MMN30
MJxMJ LONG

Use:
 For water and neutral liquids to maximum 160°F.

Tests:
 Hydraulic test to AWWA C515:
 Shell Test: 500 PSI
 Seat Test: 250 PSI
 Operating Torque Test

Optional Materials:

Stem	Bronze
Bonnet Bolts	Stainless Steel - 316 bolt sealed with hot melt
Gland Bolts, Lifting Eyes	Stainless Steel - 316

Options:
 Handwheel, Electric Actuator, Bevel Gear, Spur Gear

Approvals:

Certified to: ANSI/NSF 61, ANSI/NSF 372



Standard Materials:

Body, Bonnet, Gland Flange, Elbows	Ductile iron ASTM A536
Coating	Electrostatically applied fusion-bonded epoxy-resin Meets or exceeds AWWA C550
Wrench Nut	Ductile Iron ASTM A536 - painted black for open left, red for open right.
Stem	Standard: Stainless steel ASTM A276
Wedge	Ductile iron ASTM A536 encapsulated with EPDM-rubber compound
Wedge Nut, Thrust Collar	Bronze
Bonnet Bolts, Gland Bolts	Stainless Steel -304 sealed with hot melt
Bonnet Gasket, Wiper Ring, O-Ring Stem Seals, O-Ring Gland Seal	ASTM D2000 Buna "N" nitrile rubber

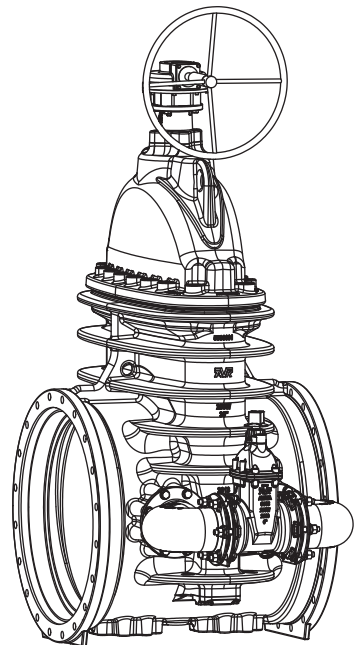

AMERICAN AVK RESILIENT SEATED GATE VALVE
250 PSI, Tested to AWWA C515 (NRS)
Mechanical Joint Ends to AWWA C111 - Valve Size 30"

55/MMN30
MJxMJ LONG

Component List:

- | | | |
|------------------------------|-----------------------------|-------------------------|
| 216. Bonnet Bolts | 231. Stem Seal Bushing | 257. Cover Plate O-ring |
| 217. Bonnet | 232. Lower Stem Seal O-Ring | 258. Cover Plate |
| 218. Bonnet Gasket | 233. Stem Rod | 259. Cover Plate Washer |
| 219. Body | 234. Thrust Collar | 260. Cover Plate Bolts |
| 226. Wiper Ring | 237. Wedge | 261. Elbow Bolt |
| 227. Gland Flange Bolt | 251. Elbow | 262. Elbow Washer |
| 228. Gland Flange | 252. Wedge Shoe | 263. Elbow Gasket |
| 229. Gland O-Ring | 255. Stem Bearing | |
| 230. Upper Stem Seal O-Rings | 256. Wedge Slotted Pin | |

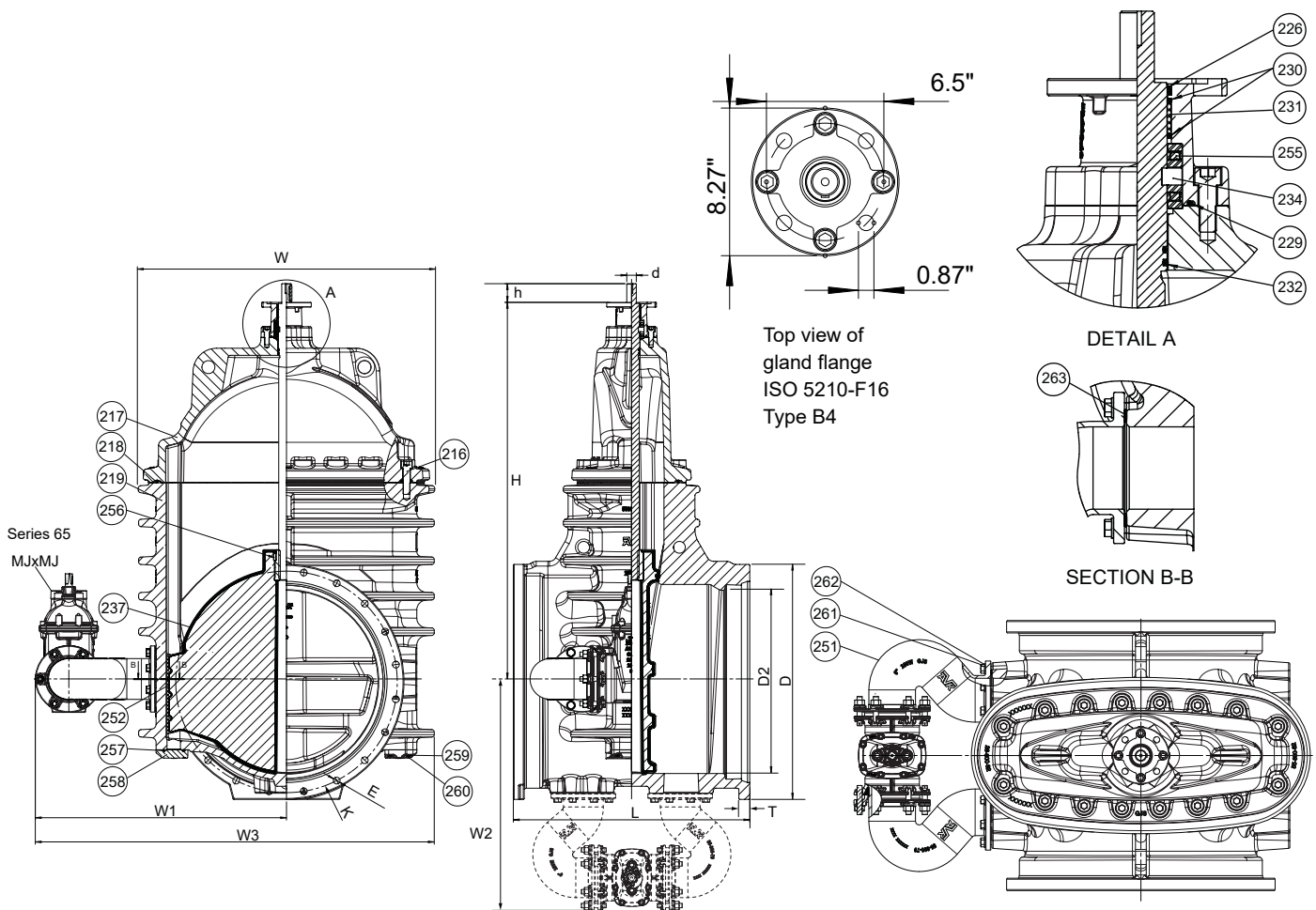

Ref. nos	Size	D	D2	d	E	H	h	K	L	T	W	W1	W2	W3	Flange Holes	Turns to open	Wt. Lbs.
55-800-MMN	30"	39.12"	30.50"	1.60"	1.13"	62.80"	3.10"	36.88"	39.00"	1.81"	49.50"	41.80"	39.12"	66.52"	20	69	5451

Add 205 Lbs. for bypass assembly
 Add 86 Lbs. for bevel gearing w/ handwheel, add 120 Lbs. for spur gearing w/ handwheel
 See Bevel & Spur Gearing datasheets for overall dimensions

