

AMERICAN AVK RESILIENT SEATED GATE VALVE
250 PSI, Tested to AWWA C515 (NRS)
Mechanical Joint Ends to AWWA C111 by
Flanged Ends to ASME B16.42 Class 150 - Valve Size 30"

55/MFN30
MJxFL LONG

Use:
 For water and neutral liquids to maximum 160°F.

Tests:
 Hydraulic test to AWWA C515:
 Shell Test: 500 PSI
 Seat Test: 250 PSI
 Operating Torque Test

Optional Materials:

Stem	Bronze
Bonnet Bolts	Stainless Steel - 316 bolt sealed with hot melt
Gland Bolts, Lifting Eyes	Stainless Steel - 316
Options: Handwheel, Electric Actuator, Bevel Gear, Spur Gear	

Approvals:
 Certified to: ANSI/NSF 61, ANSI/NSF 372



Standard Materials:

Body, Bonnet, Gland Flange, Elbows	Ductile iron ASTM A536
Coating	Electrostatically applied fusion-bonded epoxy-resin Meets or exceeds AWWA C550
Wrench Nut	Ductile Iron ASTM A536 - painted black for open left, red for open right.
Stem	Standard: Stainless steel ASTM A276
Wedge	Ductile iron ASTM A536 encapsulated with EPDM-rubber compound
Wedge Nut, Thrust Collar	Bronze
Bonnet Bolts, Gland Bolts	Stainless Steel -304 sealed with hot melt
Bonnet Gasket, Wiper Ring, O-Ring Stem Seals, O-Ring Gland Seal	ASTM D2000 Buna "N" nitrile rubber

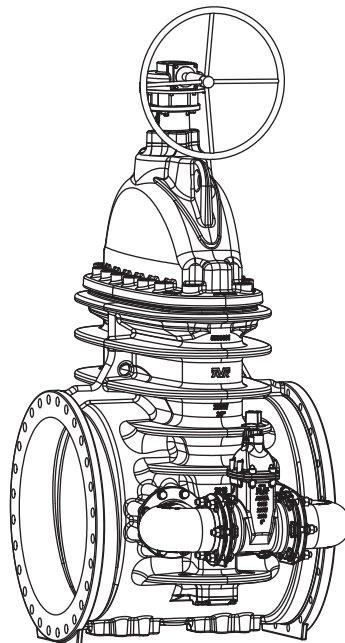

AMERICAN AVK RESILIENT SEATED GATE VALVE
250 PSI, Tested to AWWA C515 (NRS)
Mechanical Joint Ends to AWWA C111 by
Flanged Ends to ASME B16.42 Class 150 - Valve Size 30"

55/MFN30
MJxFL LONG

Component List:

- | | | |
|------------------------------|-----------------------------|-------------------------|
| 216. Bonnet Bolts | 231. Stem Seal Bushing | 257. Cover Plate O-ring |
| 217. Bonnet | 232. Lower Stem Seal O-Ring | 258. Cover Plate |
| 218. Bonnet Gasket | 233. Stem Rod | 259. Cover Plate Washer |
| 219. Body | 234. Thrust Collar | 260. Cover Plate Bolts |
| 226. Wiper Ring | 237. Wedge | 261. Elbow Bolt |
| 227. Gland Flange Bolt | 251. Elbow | 262. Elbow Washer |
| 228. Gland Flange | 252. Wedge Shoe | 263. Elbow Gasket |
| 229. Gland O-Ring | 255. Stem Bearing | |
| 230. Upper Stem Seal O-Rings | 256. Wedge Slotted Pin | |

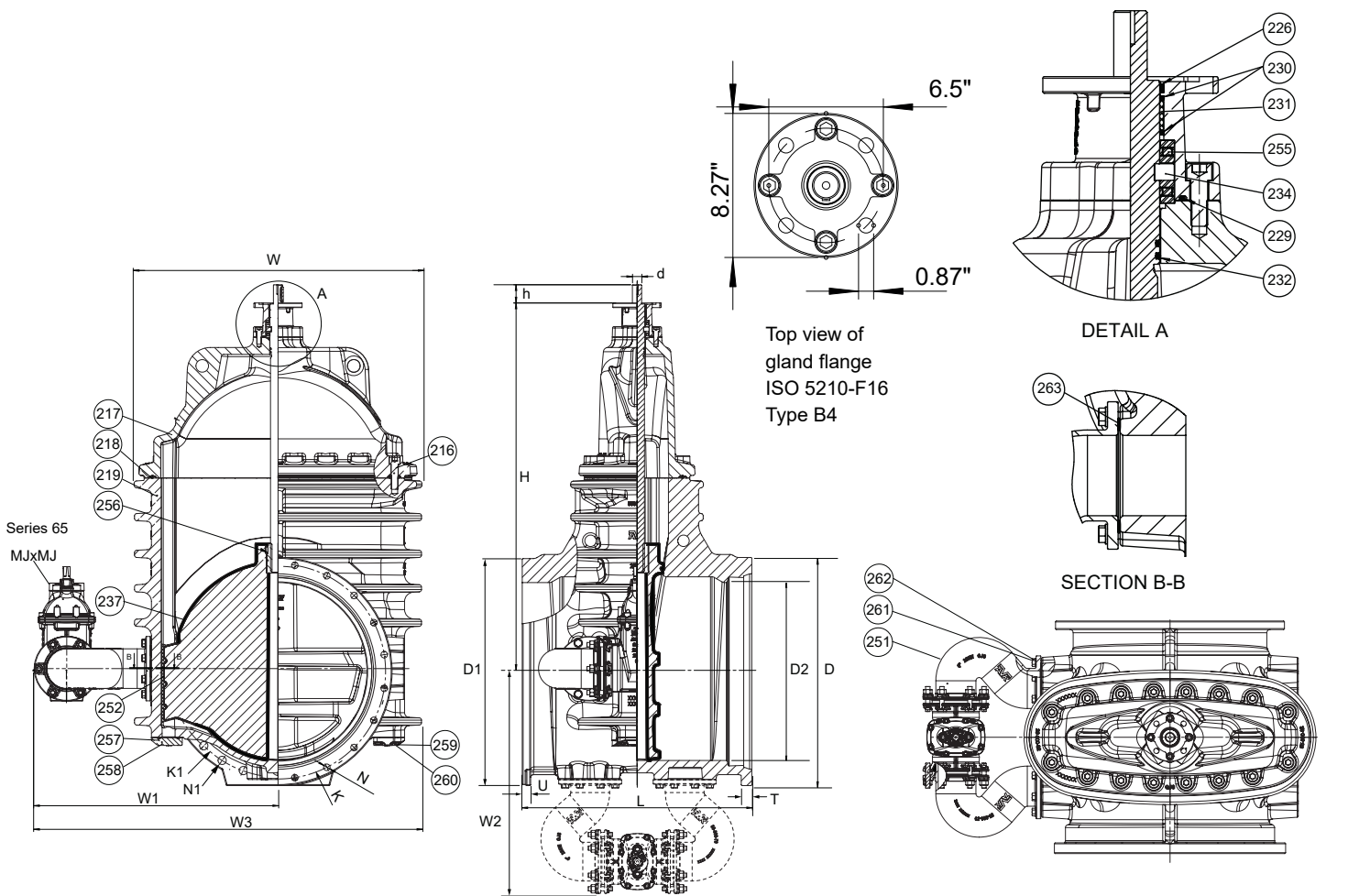

Ref. nos	Size	D	D1	D2	d	H	h	K	K1	L	N/N1	T	U	W	W1	W2	W3	FL-Holes	Turns	Wt.	
																			MJ/FL	to open	Lbs.
55-800-MFN	30"	39.12"	38.74"	30.24"	1.60"	62.80"	3.10"	36.88"	36.00"	39.00"	1.13"/1.42"	1.81"	1.44"	49.50"	41.80"	39.12"	66.52"	20/28	69	5409	

Add 205 Lbs. for bypass assembly
 Add 86 Lbs. for bevel gearing w/ handwheel, add 120 Lbs. for spur gearing w/ handwheel
 See Bevel & Spur Gearing datasheets for overall dimensions

