

AMERICAN AVK RESILIENT SEATED GATE VALVE
250 PSI, Tested to AWWA C515 (NRS)
Flanged Ends to ASME B16.42 Class 150 - Valve Size 36"

55/FFN36
FLxFL

Use:
 For water and neutral liquids to maximum 160°F.

Tests:
 Hydraulic test to AWWA C515:
 Shell Test: 500 PSI
 Seat Test: 250 PSI
 Operating Torque Test

Optional Materials:

Stem	Bronze
Bonnet Bolts	Stainless Steel - 316 bolt sealed with hot melt
Gland Bolts,	Stainless Steel - 316

Options:
 Handwheel, Electric Actuator, Bevel Gear, Spur Gear

Approvals:

Certified to: ANSI/NSF 61, ANSI/NSF 372

Certified to
ANSI/NSF 61

Certified to
ANSI/NSF 372

Standard Materials:

Body, Bonnet, Gland Flange	Ductile iron ASTM A536
Coating	Electrostatically applied fusion- bonded epoxy-resin Meets or exceeds AWWA C550
Stem	Standard: Stainless steel ASTM A276
Wedge	Ductile iron ASTM A536 encapsulated with EPDM-rubber compound
Wedge Nut, Thrust Collar	Bronze
Bonnet Bolts, Gland Bolts	Stainless Steel -304 sealed with hot melt
Bonnet Gasket, Wiper Ring, O-Ring Stem Seals, O-Ring Gland Seal	ASTM D2000 Buna "N" nitrile rubber

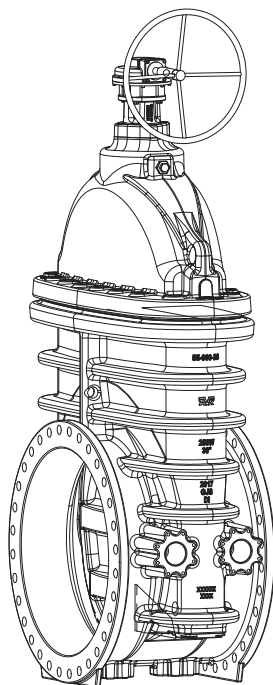

AMERICAN AVK RESILIENT SEATED GATE VALVE
250 PSI, Tested to AWWA C515 (NRS)
Flanged Ends to ASME B16.42 Class 150 - Valve Size 36"

55/FFN36
FLxFL

Component List:

- | | | |
|------------------------------|-----------------------------|--|
| 216. Bonnet Bolts | 231. Stem Seal Bushing | 257. Cover Plate O-ring |
| 217. Bonnet | 232. Lower Stem Seal O-Ring | 258. Cover Plate |
| 218. Bonnet Gasket | 233. Stem Rod | 259. Cover Plate Washer |
| 219. Body | 234. Thrust Collar | 260. Cover Plate Bolt |
| 226. Wiper Ring | 237. Wedge | 264. Upper Stem Seal O-Rings
(36 Inch Valves) |
| 227. Gland Flange Bolt | 247. Key | 265. Gland Bolt O-ring |
| 228. Gland Flange | 252. Shoe | 266. Thrust Collar Bolt |
| 229. Gland O-Ring | 255. Stem Bearing | 267. Thrust Collar Washer |
| 230. Upper Stem Seal O-Rings | 256. Wedge Slotted Pin | 268. Air Bleeder Fittings |

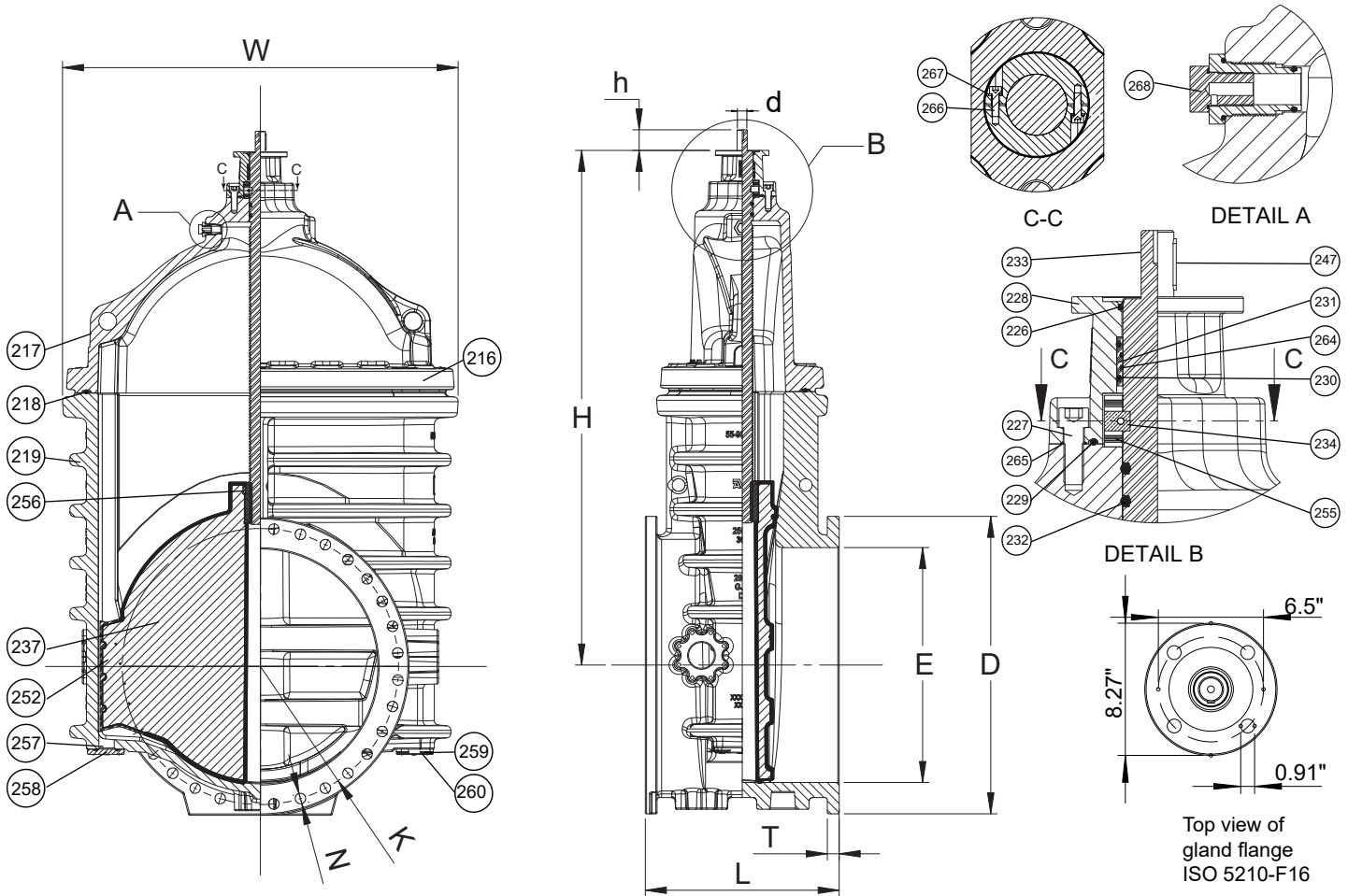

Ref. nos	Size	D	E	d	H	h	K	L	N	T	W	FL-Holes	Turns to open	Wt. Lbs.
55-900-FFN	36"	46.00"	36.37"	2.00"	79.70"	4.00"	42.75"	30.00"	1.63"	1.83"	61.34"	32	86	8332

Add 86 Lbs. for bevel gearing w/ handwheel, add 120 Lbs. for spur gearing w/ handwheel
 See Bevel & Spur Gearing datasheets for overall dimensions

