

AMERICAN AVK RESILIENT SEATED DUCTILE IRON GATE VALVE 45/PPN-UL
250 PSI, Tested to AWWA C509 / C515 (NRS)
Push-on Joint End x Push-on Joint End (TYTON®) - Valve sizes 4" - 12" and 16"
POxPO

Use:
 For water and neutral liquids to maximum 160°F.

Tests:
 Hydraulic test to AWWA C509 & UL 262:
 Shell Test: 500 PSI 4"-16"
 Seat Test: 375 PSI 4"-12" - 300 PSI -16"
 Operating Torque Test

Optional Materials:

Stem For UL, FM, ULC for 4" - 12"
 Low Zinc Bronze ASTM B763

For UL, FM, ULC for 16"
 Aluminum Bronze ASTM B150/B150M

Anti Friction Washers Polyamide

Wedge Ductile iron ASTM A536
 encapsulated with NBR-rubber
 compound

Standard Materials:

Body, Bonnet, Gland Flange, Wrench Nut Ductile iron ASTM A536
 (Wrench Nut-painted black for open left, red for open right)

Coating Electrostatically applied fusion-bonded epoxy-resin
 Meets or exceeds AWWA C550

Stem Standard: Stainless steel - 304

Wedge Ductile iron ASTM A536
 encapsulated with EPDM-rubber
 compound





Wedge Nut, Thrust Collar Bronze

Bonnet Bolts Stainless Steel - 316 sealed with hot melt

Gland Bolts Stainless Steel - 316
 Hexagon bolt

Bonnet Gasket, Wiper Ring, O-Ring Stem Seals, O-Ring Gland Seal ASTM D2000 Buna "N" nitrile rubber

Approvals:

*UL/ULC Listed
 *FM Approved
 Certified to: ANSI/NSF 61, ANSI/NSF 372

* Approved at 250 PSI working pressure, 4"-12"
 * Approved at 200 PSI working pressure, 16"

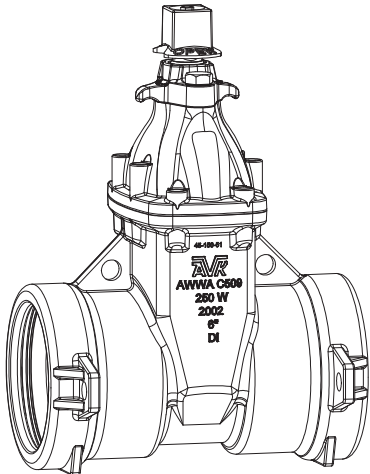

AMERICAN AVK RESILIENT SEATED DUCTILE IRON GATE VALVE

45/PPN-UL

250 PSI, Tested to AWWA C509 / C515 (NRS)

POxPO

Push-on Joint End x Push-on Joint End (TYTON®) - Valve sizes 4" - 12" and 16"

Component List:

- | | | |
|--------------------|------------------------------|-----------------------------|
| 217. Bonnet | 227. Gland Flange Bolt | 232. Lower Stem Seal O-Ring |
| 218. Bonnet Gasket | 228. Gland Flange | 233. NRS Stem |
| 219. Body | 229. Gland O-Ring | 234. Thrust Collar |
| 225. Wrench Nut | 230. Upper Stem Seal O-Rings | 237. Wedge |
| 226. Wiper Ring | 231. Stem Seal Bushing | |

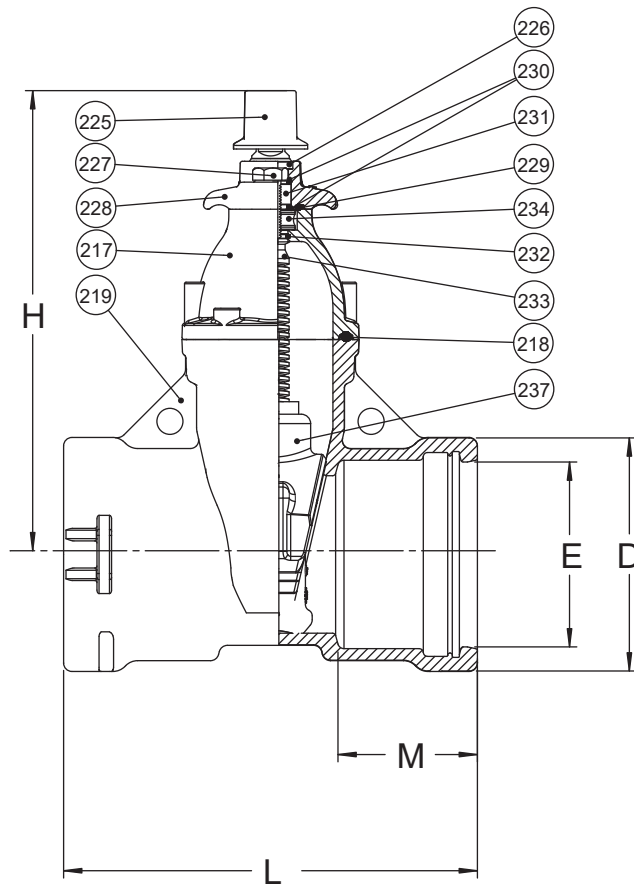

Ref No.	Size	D	E	H	L	M	Turns to Open	Weight (lbs.)
45-100-PPN	4"	6.66"	4.93"	13.50"	11.99"	4.12"	14	57
45-150-PPN	6"	8.84"	7.03"	17.50"	15.63"	5.22"	21	97
45-200-PPN	8"	11.23"	9.18"	21.50"	17.17"	5.63"	26	157
45-250-PPN	10"	13.50"	11.22"	24.75"	17.64"	5.63"	32	227
45-300-PPN	12"	15.74"	13.32"	27.75"	19.21"	5.63"	38	391
45-400-PPN	16"	20.62"	17.50"	34.75"	22.72"	6.00"	51	982

