

**AMERICAN AVK RESILIENT SEATED DUCTILE IRON GATE VALVE**  
**250 PSI, Tested to AWWA C509 / C515 (NRS) for Indicator Post**  
**Mechanical Joint by Flanged Ends to ASME B16.42 Class 150 - Valve Sizes 4" - 16"**

**45/MFP-UL**  
**MJxFL PIV**

**Use:**  
 For water and neutral liquids to maximum 160°F.

**Tests:**  
 Hydraulic test to AWWA C509 & UL 262:  
 Shell Test: 500 PSI 4"-16"  
 Seat Test: 375 PSI 4"-12" - 300 PSI 14"-16"  
 Operating Torque Test

**Optional Materials:**

**Stem** For UL, FM, ULC for 4" - 12"  
 Low Zinc Bronze ASTM B763

For UL, FM, ULC for 14" - 16"  
 Aluminum Bronze ASTM B150/B150M

**Anti Friction Washers** Polyamide

**Wedge** Ductile iron ASTM A536  
 encapsulated with NBR-rubber  
 compound

**Standard Materials:**

**Body, Bonnet, Post Indicator Plate, Wrench Nut** Ductile iron ASTM A536  
 (Wrench Nut-painted black for open left, red for open right)

**Coating** Electrostatically applied fusion-bonded epoxy-resin  
 Meets or exceeds AWWA C550

**Stem** Standard: Stainless steel - 304

**Wedge** Ductile iron ASTM A536  
 encapsulated with EPDM-rubber  
 compound





**Wedge Nut, Thrust Collar** Bronze

**Bonnet Bolts** Stainless Steel - 316 sealed with  
 hot melt

**Gland Bolts** Stainless Steel - 316  
 Hexagon bolt

**Bonnet Gasket, Wiper Ring, O-Ring Stem Seals, O-Ring Gland Seal** ASTM D2000 Buna "N" nitrile  
 rubber

**Approvals:**

\*UL/ULC Listed  
 \*FM Approved  
 Certified to: ANSI/NSF 61, ANSI/NSF 372

\* Approved at 250 PSI working pressure, 4"-12"  
 \* Approved at 200 PSI working pressure, 14"-16"

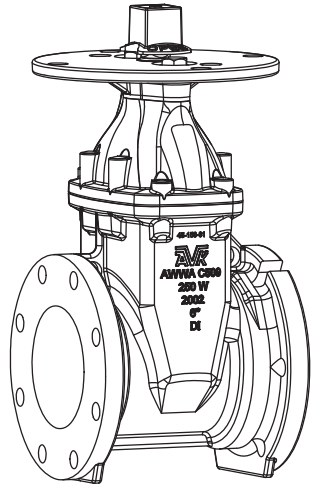

**AMERICAN AVK RESILIENT SEATED DUCTILE IRON GATE VALVE**  
**250 PSI, Tested to AWWA C509 / C515 (NRS) for Indicator Post**  
**Mechanical Joint by Flanged Ends to ASME B16.42 Class 150 - Valve Sizes 4" - 16"**

**45/MFP-UL**  
**MJxFL PIV**

Component List:

- |                           |                              |                             |
|---------------------------|------------------------------|-----------------------------|
| 217. Bonnet               | 226. Wiper Ring              | 232. Lower Stem Seal O-Ring |
| 218. Bonnet Gasket        | 227. Gland Flange Bolt       | 233. NRS Stem               |
| 219. Body                 | 229. Gland O-Ring            | 234. Thrust Collar          |
| 224. Post Indicator Plate | 230. Upper Stem Seal O-Rings | 237. Wedge                  |
| 225. Wrench Nut           | 231. Stem Seal Bushing       |                             |

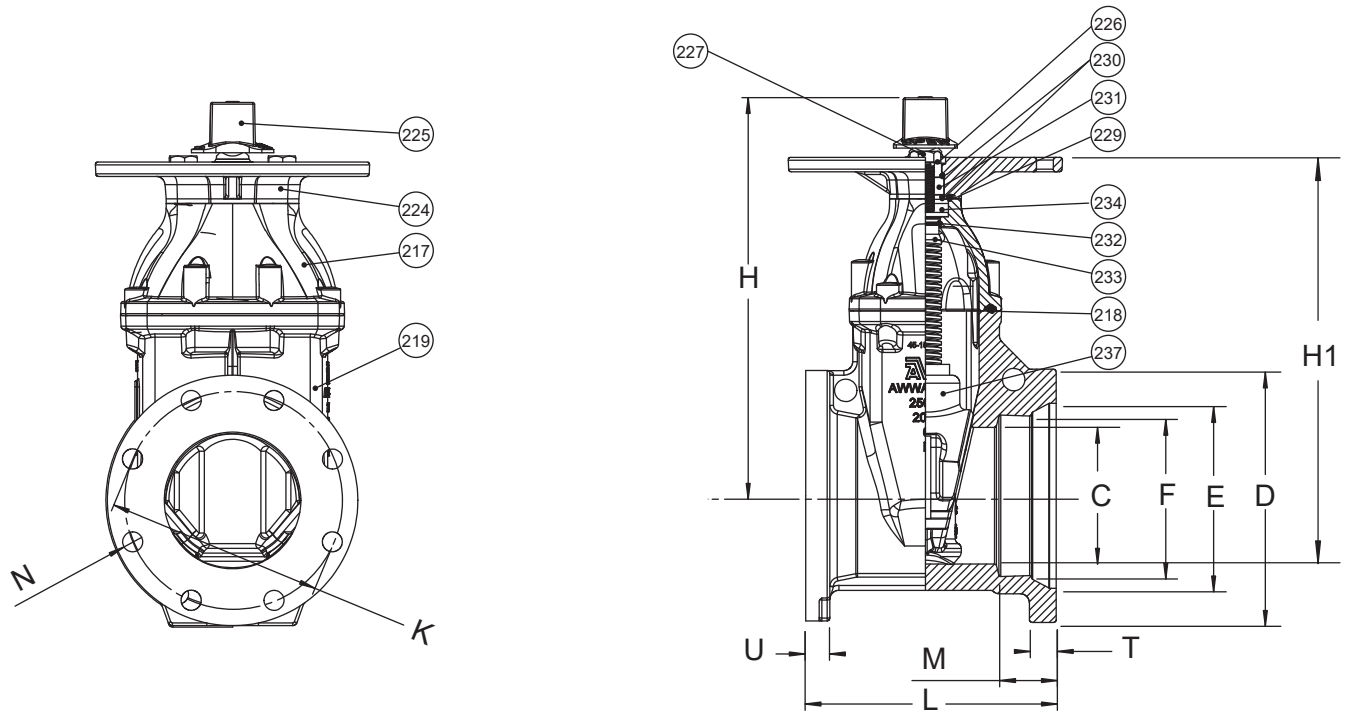

| Ref No.       | Size | C      | D      | E      | F      | H      | H1     | K      | L      | M     | N     | T     | U     | Flange Holes | Turns to Open | Weight (lbs.) |
|---------------|------|--------|--------|--------|--------|--------|--------|--------|--------|-------|-------|-------|-------|--------------|---------------|---------------|
| 45-100-MFP-UL | 4"   | 4.25"  | 9.12"  | 6.02"  | 4.90"  | 13.50" | 13.00" | 7.50"  | 9.00"  | 2.50" | 0.75" | 1.00" | 1.00" | 8            | 14            | 78            |
| 45-150-MFP-UL | 6"   | 6.25"  | 11.12" | 8.12"  | 7.00"  | 17.50" | 18.00" | 9.50"  | 10.50" | 2.50" | 0.88" | 1.18" | 1.06" | 8            | 20            | 112           |
| 45-200-MFP-UL | 8"   | 8.25"  | 13.37" | 10.27" | 9.15"  | 21.50" | 23.00" | 11.75" | 11.50" | 2.50" | 0.88" | 1.24" | 1.14" | 8            | 26            | 169           |
| 45-250-MFP-UL | 10"  | 10.25" | 15.69" | 12.34" | 11.20" | 24.75" | 27.00" | 14.25" | 13.00" | 2.50" | 1.00" | 1.14" | 1.22" | 12           | 32            | 284           |
| 45-300-MFP-UL | 12"  | 12.25" | 17.88" | 14.44" | 13.30" | 27.63" | 31.00" | 17.00" | 14.00" | 2.50" | 1.00" | 1.22" | 1.30" | 12           | 38            | 424           |
| 45-350-MFP-UL | 14"  | 14.00" | 20.31" | 16.61" | 15.50" | 35.75" | 39.00" | 18.75" | 15.00" | 3.50" | 1.13" | 1.32" | 1.40" | 12           | 51            | 635           |
| 45-400-MFP-UL | 16"  | 16.00" | 22.56" | 18.64" | 17.54" | 34.75" | 42.00" | 21.25" | 16.00" | 3.50" | 1.13" | 1.34" | 1.44" | 16           | 51            | 805           |

