

AMERICAN AVK RESILIENT SEATED DUCTILE IRON GATE VALVE 45/GGP-UL Tested to AWWA C509 (NRS) for Indicator Post IPS Grooved End according to AWWA C606 - Valve Sizes 2½" - 10"

Use:

For water and neutral liquids to maximum 160°F.

Tests:

Hydraulic test to AWWA C509 & UL 262:

Shell Test: 500 PSI 2.5"-10"

Seat Test: 375 PSI 2.5"-10"

Operating Torque Test

Optional Materials:

Stem For UL, FM, ULC
 Low Zinc Bronze ASTM B763

Anti Friction Washers Polyamide

Wedge Ductile iron ASTM A536
 encapsulated with NBR-rubber
 compound

Standard Materials:
 Body, Bonnet,
 Post Indicator Plate,
 Wrench Nut

Ductile iron ASTM A536
 (Wrench Nut-painted black for
 open left, red for open right)

Coating

Electrostatically applied fusion-
 bonded epoxy-resin
 Meets or exceeds AWWA C550

Stem

Stainless steel 304

Wedge

Ductile iron ASTM A536
 encapsulated with EPDM-rubber
 compound

Wedge Nut, Thrust Collar Bronze

Bonnet Bolts Stainless Steel - 316
 sealed with hot melt

Gland Bolts Stainless Steel - 316
 Hexagon bolt

**Bonnet Gasket,
 Wiper Ring,
 O-Ring Stem Seals,
 O-Ring Gland Seal** ASTM D2000 Buna "N" nitrile
 rubber

Approvals:



*UL/ULC Listed
 *FM Approved
 Certified to: ANSI/NSF 61, ANSI/NSF 372

* Approved at 250 PSI working pressure, 2.5"-10"

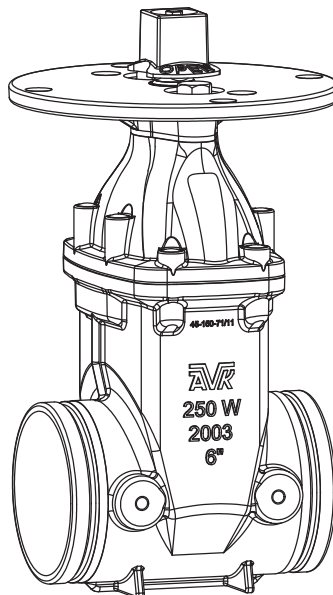

AMERICAN AVK RESILIENT SEATED DUCTILE IRON GATE VALVE 45/GGP-UL
Tested to AWWA C509 (NRS) for Indicator Post
IPS Grooved End according to AWWA C606 - Valve Sizes 2½" - 10"

Component List:

- | | | |
|---------------------------|------------------------------|-----------------------------|
| 217. Bonnet | 226. Wiper Ring | 232. Lower Stem Seal O-Ring |
| 218. Bonnet Gasket | 227. Gland Flange Bolt | 233. NRS Stem |
| 219. Body | 229. Gland O-Ring | 234. Thrust Collar |
| 224. Post Indicator Plate | 230. Upper Stem Seal O-Rings | 237. Wedge |
| 225. Wrench Nut | 231. Stem Seal Bushing | |

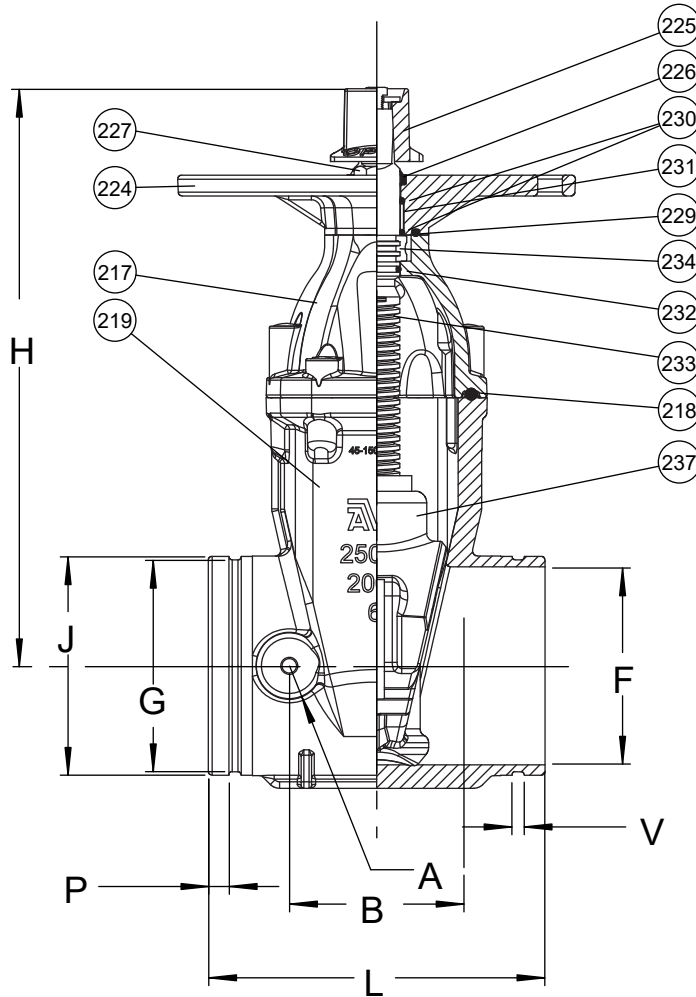

Ref No.	Size	A	B	F	G	H	J	L	P	V	Turns to Open	Weight Lbs.
45-065-GGP-UL	2.5"	1.57"	3.74"	2.50"	2.72"	12.50"	2.88"	8.00"	0.63"	0.31"	12	30
45-080-GGP-UL	3"	1.57"	3.74"	3.00"	3.34"	12.50"	3.50"	8.00"	0.63"	0.31"	13	35
45-100-GGP-UL	4"	1.65"	4.12"	4.00"	4.33"	13.50"	4.50"	9.00"	0.63"	0.38"	14	46
45-150-GGP-UL	6"	1.97"	5.29"	6.00"	6.45"	17.50"	6.62"	10.50"	0.63"	0.38"	21	87
45-200-GGP-UL	8"	1.97"	8.00"	8.00"	8.44"	21.50"	8.62"	11.50"	0.75"	0.44"	26	133
45-250-GGP-UL	10"	1.97"	8.00"	10.00"	10.53"	24.75"	10.75"	13.00"	0.75"	0.50"	32	185

