

**AMERICAN AVK RESILIENT SEATED DUCTILE IRON GATE VALVE 65/HHN-WD**  
**250 PSI, Tested to AWWA C515 (NRS)**  
**HYMAX GRIP® - Valve sizes 1½" - 12"**  
**HYxHY**

**Use:**

For water and neutral liquids to maximum 160°F.

**Tests:**

Hydraulic test to AWWA C515:

Shell Test: 500 PSI

Seat Test: 250 PSI

Operating Torque Test

**Optional Materials:**

Wedge                      Ductile iron ASTM A536  
 encapsulated with NBR-rubber  
 compound

**Standard Materials:**

Body, Bonnet, Gland Flange, Wrench Nut	Ductile iron ASTM A536 (Wrench Nut-painted black for open left, red for open right)
Coating	Electrostatically applied fusion- bonded epoxy-resin Meets or exceeds AWWA C550
Stem	Standard: Stainless steel 430F
Wedge	Ductile iron ASTM A536 encapsulated with EPDM-rubber compound
Wedge Nut, Thrust Collar	Bronze
Bonnet Bolts	Stainless Steel - 316 sealed with hot melt
Gland Bolts	Stainless Steel - 316 Hexagon bolt
Bonnet Gasket, Wiper Ring, O-Ring Stem Seals, O-Ring Gland Seal	ASTM D2000 Buna "N" nitrile rubber

**Approvals:**

Certified to: ANSI/NSF 61, ANSI/NSF 372

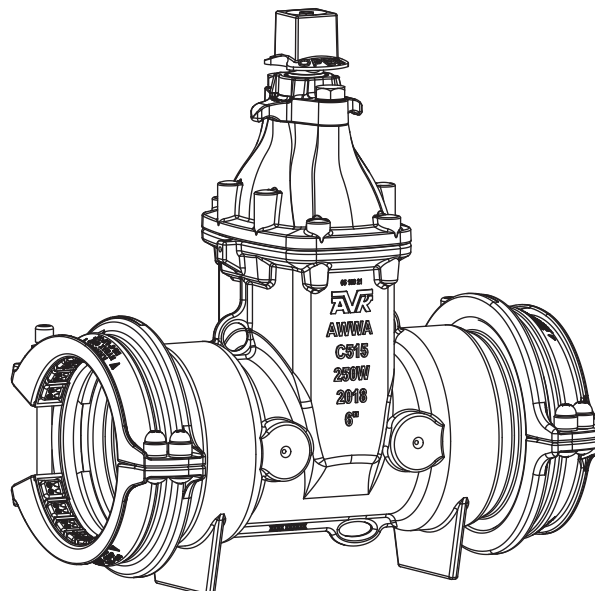

**AMERICAN AVK RESILIENT SEATED DUCTILE IRON GATE VALVE**  
**250 PSI, Tested to AWWA C515 (NRS)**  
**HYMAX GRIP® - Valve sizes 1½" - 12"**

**65/HHN-WD**  
**HYxHY**

Component List:

- |                    |                              |                             |
|--------------------|------------------------------|-----------------------------|
| 217. Bonnet        | 227. Gland Flange Bolt       | 232. Lower Stem Seal O-Ring |
| 218. Bonnet Gasket | 228. Gland Flange            | 233. NRS Stem               |
| 219. Body          | 229. Gland O-Ring            | 234. Thrust Collar          |
| 225. Wrench Nut    | 230. Upper Stem Seal O-Rings | 237. Wedge                  |
| 226. Wiper Ring    | 231. Stem Seal Bushing       |                             |

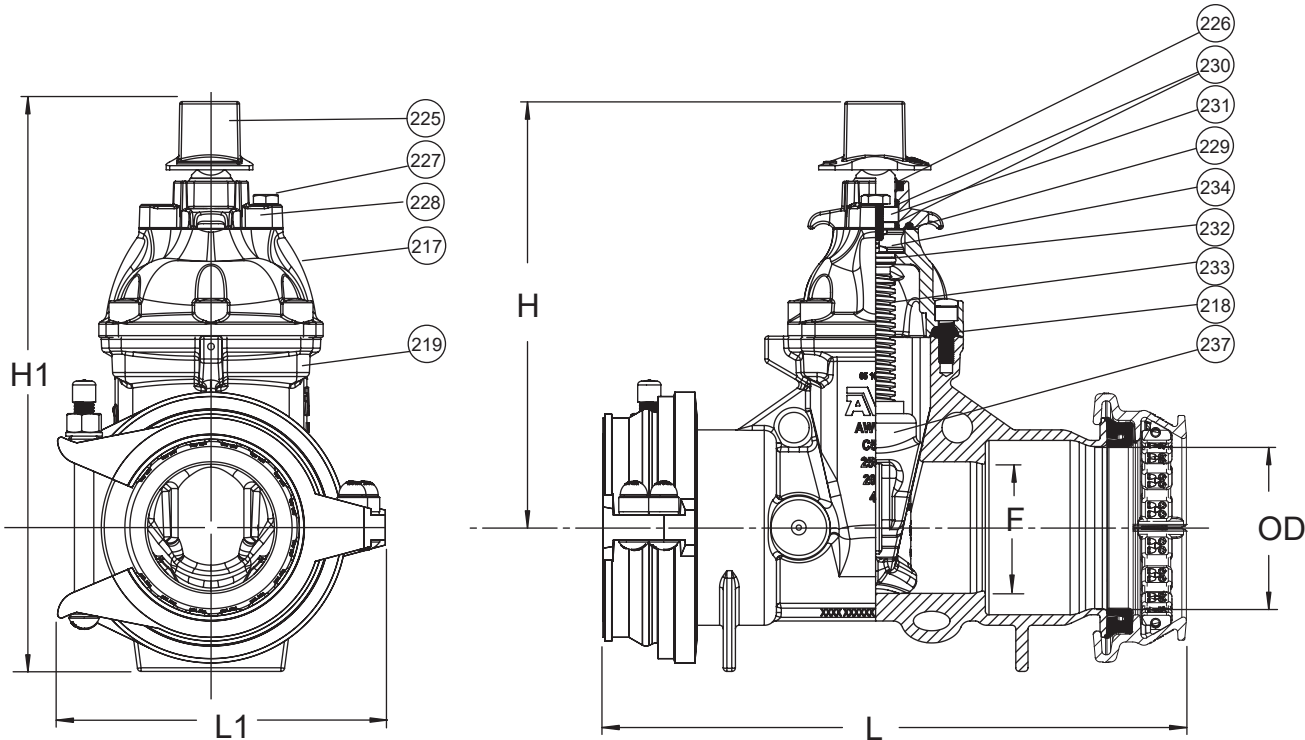

Ref No.	Size	Pipe OD Min/Max	F	H	H1	L	L1	Turns to Open	Weight (lbs.)
65-050-HHN	1.5"-2"***	1.54"/2.64"	1.97"	12.30"	15.65"	15.20"	7.48"	10	44
65-065-HHN	2.5"	2.32"/3.43"	2.63"	12.65"	16.00"	15.20"	8.07"	12	47
65-080-HHN	3"	3.15"/4.17"	3.13"	13.25"	17.50"	18.50"	9.06"	14	59
65-100-HHN	4"	4.40"/5.10"	4.10"	13.82"	18.47"	20.46"	10.60"	16	83
65-150-HHN	6"	6.50"/7.20"	6.18"	17.81"	23.91"	21.80"	12.90"	21	131
65-200-HHN	8"	8.50"/9.40"	8.19"	21.83"	29.31"	23.75"	15.70"	27	193
65-250-HHN	10"	10.65"/11.55"	10.25"	25.06"	33.72"	24.83"	18.20"	33	279
65-300-HHN	12"	12.68"/13.39"	12.25"	27.96"	37.41"	24.50"	19.80"	39	349

\*\* Note: The 2" valve has a 1.5" adaptor gasket installed that must be removed for 2" use.

The 2.5" and 3" valves also have adaptor gasket

Min. Coupling Torque - Ft. Lbs.

- |        |      |
|--------|------|
| 2"-3"  | -70  |
| 4"     | -90  |
| 6"     | -110 |
| 8"-12" | -200 |

