

AMERICAN AVK RESILIENT SEATED DUCTILE IRON GATE VALVE 45/PFN-WD
250/350 PSI, Tested to AWWA C509 / C515 (NRS)
Push-on Joint End (TYTON) x Flanged End to ASME B16.42 Class 150 - Valve sizes 4" - 12" and 16"
POxFL

Use:

For water and neutral liquids to maximum 160°F.

Tests:

Hydraulic test to AWWA C509:

Shell Test: 700 PSI 3"-12"

Seat Test: 350 PSI 3"-12"

Shell Test: 500 PSI 16"

Seat Test: 250 PSI 16"

Operating Torque Test

Optional Materials:

Wedge Ductile iron ASTM A536
 encapsulated with NBR-rubber
 compound

Stem 304 stainless steel

Standard Materials:

Body, Bonnet, Ductile iron ASTM A536
 Gland Flange, (Wrench Nut-painted black for
 Wrench Nut open left, red for open right)

Coating Electrostatically applied fusion-
 bonded epoxy-resin
 Meets or exceeds AWWA C550

Stem Standard: Stainless steel 430F

Wedge Ductile iron ASTM A536
 encapsulated with EPDM-rubber
 compound

Wedge Nut, Thrust Collar Bronze

Bonnet Bolts Stainless Steel - 316 sealed with
 hot melt

Gland Bolts Stainless Steel - 316
 Hexagon bolt

Bonnet Gasket, ASTM D2000 Buna "N" nitrile
 Wiper Ring, rubber
 O-Ring Stem Seals,
 O-Ring Gland Seal

Approvals:

Certified to: ANSI/NSF 61, ANSI/NSF 372

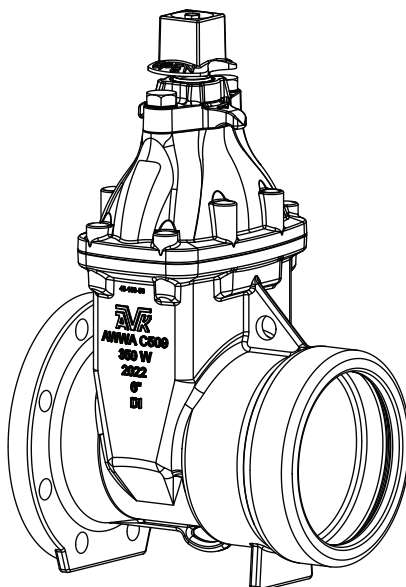

AMERICAN AVK RESILIENT SEATED DUCTILE IRON GATE VALVE 45/PFN-WD
250/350 PSI, Tested to AWWA C509 / C515 (NRS)
Push-on Joint End (TYTON) x Flanged End to ASME B16.42 Class 150 - Valve sizes 4" - 12" and 16"
POxFL

Component List:

- | | | |
|--------------------|------------------------------|-----------------------------|
| 217. Bonnet | 227. Gland Flange Bolt | 232. Lower Stem Seal O-Ring |
| 218. Bonnet Gasket | 228. Gland Flange | 233. NRS Stem |
| 219. Body | 229. Gland O-Ring | 234. Thrust Collar |
| 225. Wrench Nut | 230. Upper Stem Seal O-Rings | 237. Wedge |
| 226. Wiper Ring | 231. Stem Seal Bushing | |

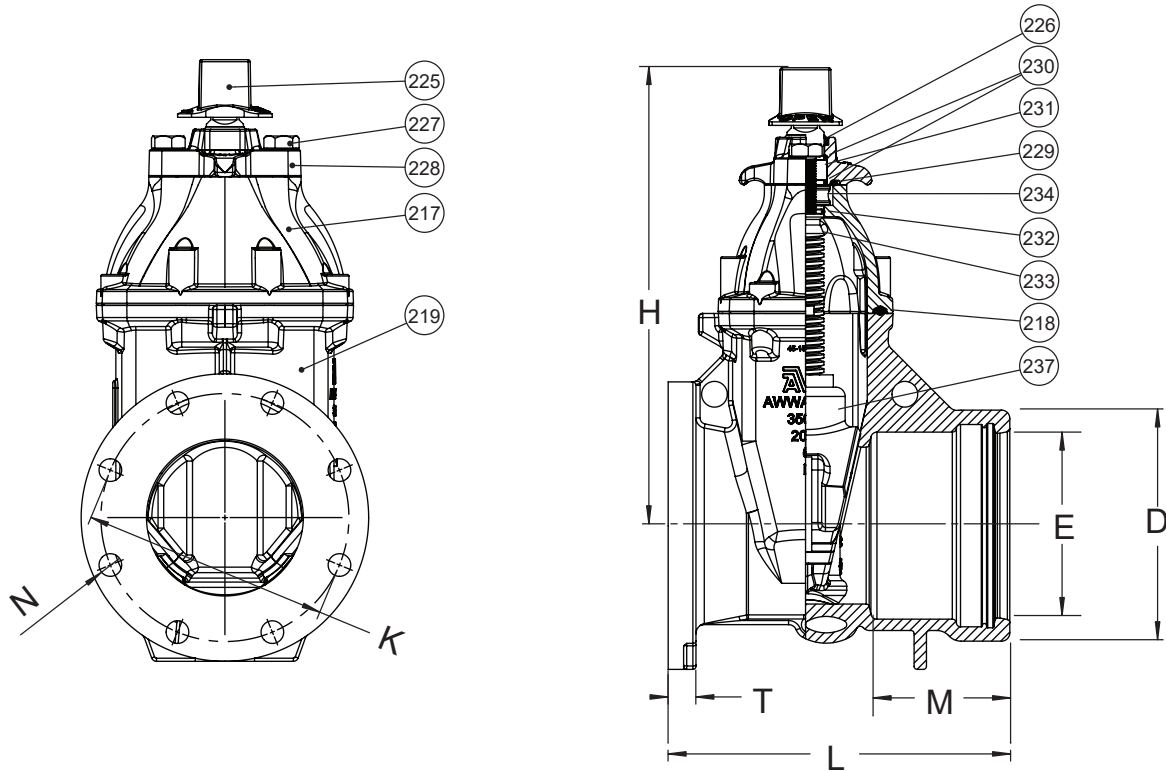

Ref No.	Size	Working Pressure	D	E	H	K	L	M	N	T	Flange Holes	Turns to Open	Weight (lbs.)
45-100-PFN-WD	4"	350	6.66"	4.93"	13.50"	7.51"	10.51"	4.12"	0.75"	1.00"	8	14	59
45-150-PFN-WD	6"	350	8.84"	7.03"	17.50"	9.49"	13.07"	5.22"	0.88"	1.06"	8	20	98
45-200-PFN-WD	8"	350	11.23"	9.18"	21.50"	11.73"	14.33"	5.63"	0.88"	1.14"	8	26	154
45-250-PFN-WD	10"	350	13.50"	11.22"	24.75"	14.25"	15.31"	5.63"	1.00"	1.22"	12	32	232
45-300-PFN-WD	12"	350	15.74"	13.32"	27.75"	17.00"	16.61"	5.63"	1.00"	1.30"	12	38	358
45-400-PFN-WD	16"	250	20.62"	17.51"	34.75"	21.25"	19.35"	5.00"	1.13"	1.44"	12	51	800

