

AMERICAN AVK RESILIENT SEATED DUCTILE IRON GATE VALVE 45/MMC-WD
350 PSI, Tested to AWWA C509 / C515 (NRS)
Mechanical Joint Ends - Cut-In - Valve Sizes 4" - 12" **45/MMC-WD**
MJxMJ/CUT-IN

Use:
 For water and neutral liquids to maximum 160°F.

Tests:
 Hydraulic test to AWWA C509:
 Shell Test: 700 PSI 3"-12"
 Seat Test: 350 PSI 3"-12"
 Shell Test: 500 PSI 14"-16"
 Seat Test: 250 PSI 14"-16"
 Operating Torque Test

Optional Materials:

Wedge	Ductile iron ASTM A536 encapsulated with NBR-rubber compound
Stem	304 stainless steel

Standard Materials:

Body, Bonnet, Gland Flange, Wrench Nut	Ductile iron ASTM A536 (Wrench Nut-painted black for open left, red for open right)
Coating	Electrostatically applied fusion-bonded epoxy-resin Meets or exceeds AWWA C550
Stem	Standard: Stainless steel 430F
Wedge	Ductile iron ASTM A536 encapsulated with EPDM-rubber compound
Wedge Nut, Thrust Collar	Bronze
Bonnet Bolts	Stainless Steel - 316 sealed with hot melt
Gland Bolts	Stainless Steel - 316 Hexagon bolt
Bonnet Gasket, Wiper Ring, O-Ring Stem Seals, O-Ring Gland Seal	ASTM D2000 Buna "N" nitrile rubber

Approvals:

Certified to:
ANSI/NSF 61, ANSI/NSF 372





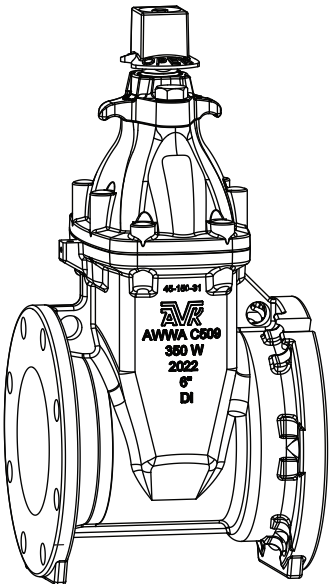

AMERICAN AVK RESILIENT SEATED DUCTILE IRON GATE VALVE
350 PSI, Tested to AWWA C509 / C515 (NRS)
Mechanical Joint Ends - Cut-In - Valve Sizes 4" - 12"

45/MMC-WD
MJxMJ/CUT-IN

Component List:

- | | | |
|--------------------|------------------------------|-----------------------------|
| 217. Bonnet | 227. Gland Flange Bolt | 232. Lower Stem Seal O-Ring |
| 218. Bonnet Gasket | 228. Gland Flange | 233. NRS Stem |
| 219. Body | 229. Gland O-Ring | 234. Thrust Collar |
| 225. Wrench Nut | 230. Upper Stem Seal O-Rings | 237. Wedge |
| 226. Wiper Ring | 231. Stem Seal Bushing | |

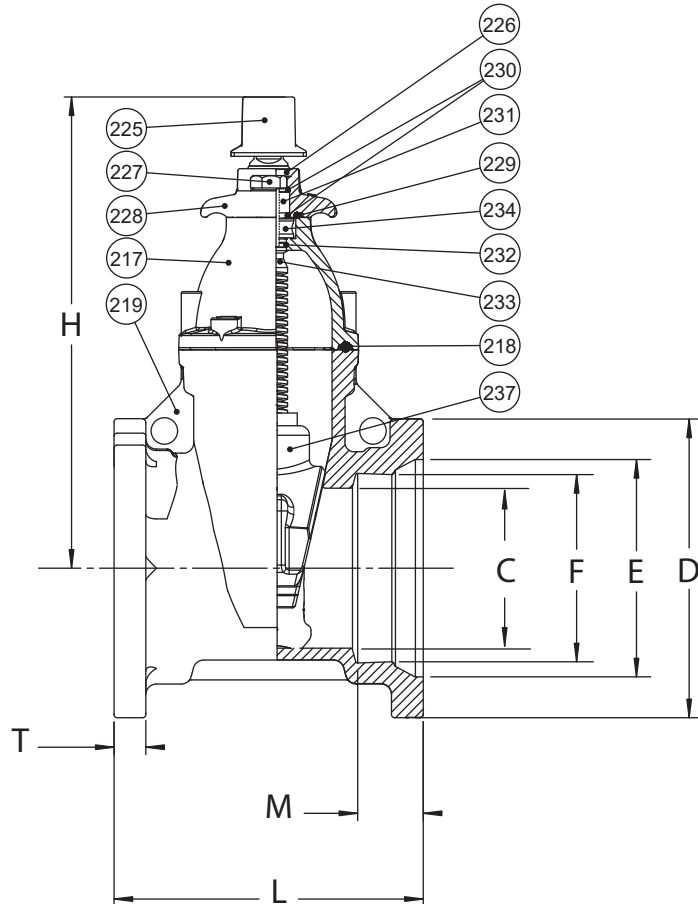

Ref No.	Size	Working Pressure	C	D	E	F	H	L	M	T	Turns to Open	Wt. Lbs.
45-101-MMC-WD	4"	350	4.25"	9.12"	6.02"	5.17"	13.50"	10.00"	2.53"	1.00"	14	62
45-151-MMC-WD	6"	350	6.25"	11.12"	8.12"	7.27"	17.50"	11.50"	2.53"	1.18"	20	103
45-201-MMC-WD	8"	350	8.25"	13.37"	10.27"	9.47"	21.50"	11.50"	2.55"	1.24"	26	155
45-251-MMC-WD	10"	350	10.25"	15.69"	12.34"	11.60"	24.75"	13.00"	2.55"	1.14"	32	240
45-301-MMC-WD	12"	350	12.25"	17.88"	14.44"	13.54"	27.63"	14.00"	2.55"	1.22"	38	337

