

# AVK DOUBLE ECCENTRIC BUTTERFLY VALVE

766/BFV/ROT/GB

Resilient Seated - 150 or 250 PSI rated working pressures to AWWA C504, ABOVE GROUND

FLxFL

Flanged Ends to ANSI B16.42 Class 150 - Valve Sizes 24" - 48"

### Use:

For water to maximum 160°F.

### Tests:

Hydraulic tests:

150 PSI working pressure

Shell Test: 300 PSI

Seat Test: 150 PSI\*

250 PSI working pressure

Shell Test: 500 PSI

Seat Test: 250 PSI\*

\* Single direction standard. Bi-directional testing available for additional fee.

### Standard Materials:

Body, Disc Body,	Ductile iron ASTM A536
End Plate	
Seat Ring	316 stainless steel
Dowel Pins	431 stainless steel
Coating	AWWA C550 Epoxy
Stems	150 PSI - 431 stainless steel 250 PSI - 17-4PH stainless steel
Bushings	Copper alloy ASTM B505
Hardware	316 stainless steel
Rubber Disc Seal,	EPDM rubber
Cover Plate O-ring	ASTM D2000 Buna "N" nitrile
Disc Gasket, Misc. O-rings	rubber
Axial Bearings	Steel with PTFE
Axial Thrust Bearing	Copper Bronze
O-Ring Retainers	Aluminum Bronze

### Approvals:

Certified to: ANSI/NSF 61, ANSI/NSF 372

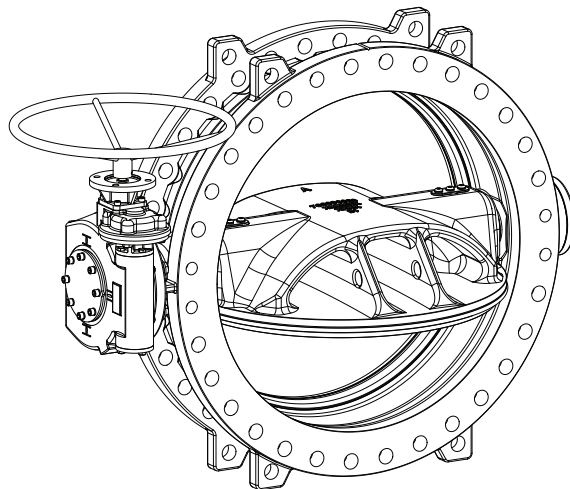

# AVK DOUBLE ECCENTRIC BUTTERFLY VALVE

766/BFV/ROT/GB

Resilient Seated - 150 or 250 PSI rated working pressures to AWWA C504, ABOVE GROUND

FLxFL

Flanged Ends to ANSI B16.42 class 150 - Valve Sizes 24" - 48"

## Component List:

801. Body	827. End Plate Bolts	851. Disc Pin	867. Disc Cover O-ring
805. Drive Shaft	836. Upper O-ring Retainer Screws*	855. Axial Bearing O-ring	868. Disc Cover Gasket
806. Stub Shaft	837. Upper O-ring Retainer Inner O-rings	856. Axial Thrust Bearing Gasket	869. Disc Cover
807. Disc Body	838. Upper O-ring Retainer Outer O-rings	857. Axial Thrust Bearing Mounting Screws	870. Disc Cover Mounting Screws*
810. Gearbox Key*	839. Upper O-ring Retainer	858. Axial Thrust Bearing Adjustment Screws*	871. Disc Seal Retainer O-ring
811. Gearbox	841. Safety Key*	859. Axial Thrust Bearing	872. Disc Seal
812. Handwheel	843. End Plate Dust O-ring	860. Lower O-ring Retainer Mounting Screws	873. Disc Seal Retainer Mounting Screw O-rings*
814. Gearbox Bolt	845. Pin Screw	861. Lower O-ring Retainer Inner O-rings	874. Disc Seal Retainer
815. Gearbox Washer	846. Pin Lock Washer	862. Lower O-ring Retainer	875. Disc Seal Retainer Mounting Screw Washers*
816. Handwheel Screw*	847. Outer Pin O-ring	863. Lower O-ring Retainer Outer O-rings	876. Disc Seal Retainer Mounting Screws*
821. Axial Bearing	848. Pin Safety Plate	864. Seat Mounting Screws	
825. End Plate	849. Pin Washer	865. Seat Ring	
826. End Plate Washers	850. Inner Pin O-ring	866. Seat Ring O-ring*	

\* Not shown

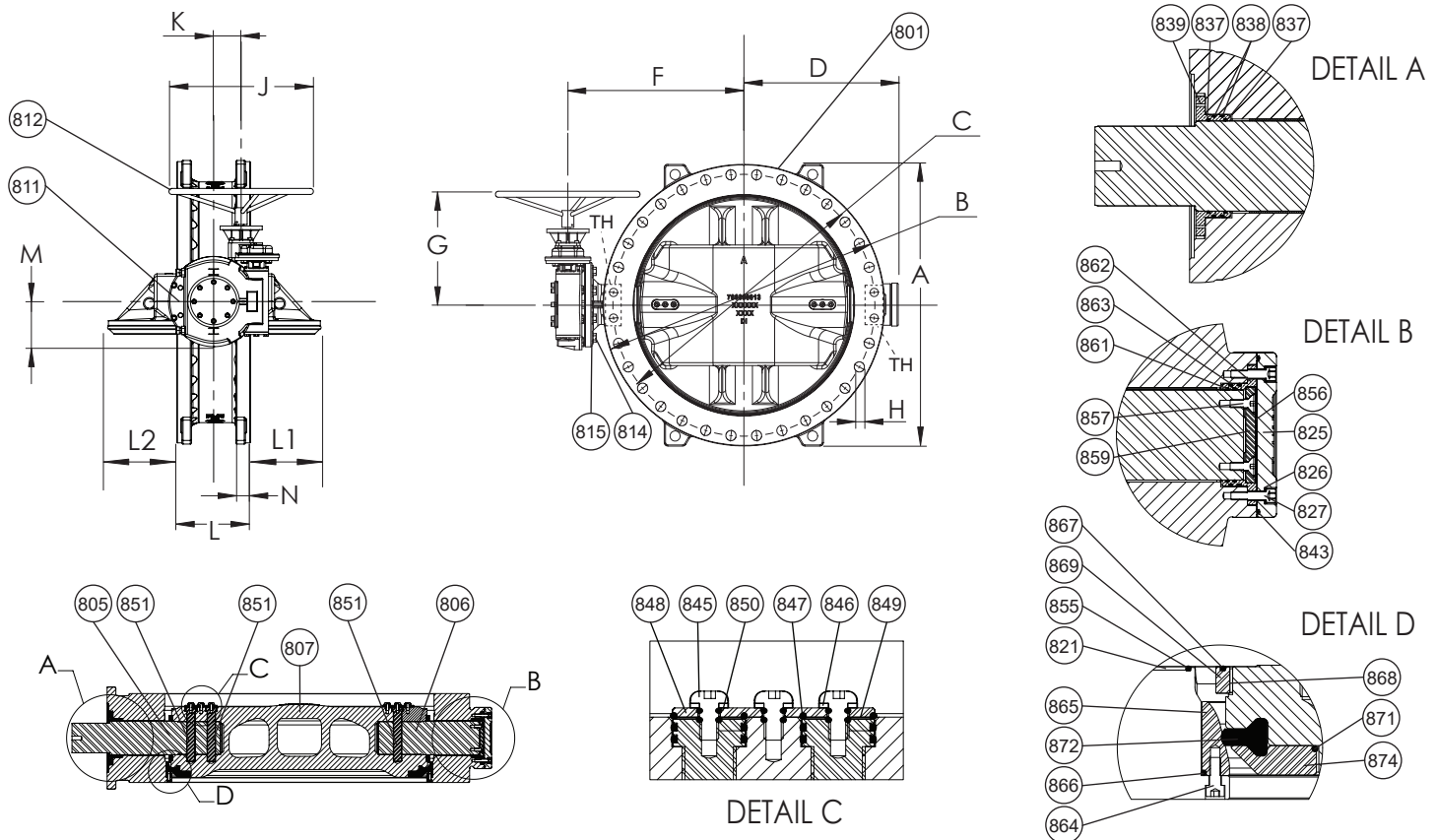

Ref No.	Size	A	B	C	D	F	G	H	J	K	L	L1	L2	M	N	TURNS		NO. OF	SHPG.
																TO OPEN	HL/TH*		
766-0600-FF-RGB	24"	32.40"	32.00"	29.50"	17.47"	24.93"	16.53"	1.38"	23.62"	5.35"	8.00"	7.60"	7.84"	5.61"	1.88"	24	16/4	936	
766-0750-FF-RGB	30"	39.13"	38.74"	36.00"	20.90"	27.48"	16.53"	1.38"	23.62"	7.00"	12.00"	8.39"	8.63"	7.38"	2.13"	38	24/4	1684	
766-0900-FF-RGB	36"	46.38"	45.98"	42.75"	25.04"	33.82"	22.72"	1.65"	23.62"	8.28"	12.00"	11.39"	11.62"	8.86"	2.38"	64	28/4	2490	
766-1050-FF-RGB	42"	53.39"	52.99"	49.50"	28.80"	37.62"	22.72"	1.65"	23.62"	8.28"	12.00"	14.41"	14.65"	8.86"	2.63"	64	32/4	3715	
766-1200-FF-RGB	48"	59.84"	59.49"	56.00"	32.72"	44.45"	24.41"	1.65"	23.62"	9.69"	15.00"	15.60"	16.62"	10.24"	2.75"	128	40/4	5029	

\* HL/TH - Holes/Threaded per flange - sizes 0600-0750 = 1 1/4" x7 threads - sizes 0900-1200 = 1 1/2" x 6 threads

