

AMERICAN AVK RESILIENT SEATED GATE VALVE
250 PSI, Tested to AWWA C509/C515 (NRS)
Mechanical Joint Ends - Valve Sizes 18" - 24"

55/MMN/WD
MJxMJ

Use:

For water and neutral liquids to maximum 160°F.

Tests:

Hydraulic test to AWWA C509/C515:

Shell Test: 500 PSI

Seat Test: 250 PSI

Operating Torque Test

Options:

Stem	Low Zinc Bronze
Thrust Collar	Stainless steel
Wedge	Ductile iron ASTM A536 encapsulated with NBR-rubber compound

Approvals:

Certified to: NSF/ANSI/CAN 61, NSF/ANSI/CAN 372



Certified to
NSF/ANSI/CAN 61
& 372

Standard Materials:

Body, Bonnet, Gland Flange, Wrench Nut	Ductile iron ASTM A536 (Wrench Nut-painted black for open left, red for open right)
Wedge	Ductile iron ASTM A536 encapsulated with EPDM-rubber compound
Stem	430F stainless steel
Radial Bearing, Wedge Shoe	Polyamide
Coating	Electrostatically applied fusion- bonded epoxy-resin Meets or exceeds AWWA C550
Wedge Nut	Copper alloy
Thrust Collar	Aluminum Bronze
Thrust Bearing	Bronze/PTFE composite
Bonnet Bolts, Gland Bolts	Stainless Steel - 316 sealed with hot melt
Bonnet Gasket, Wiper Ring, O-rings	ASTM D2000 Buna "N" nitrile rubber

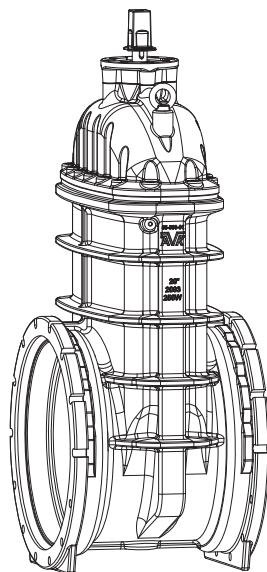

AMERICAN AVK RESILIENT SEATED GATE VALVE
250 PSI, Tested to AWWA C509/C515 (NRS)
Mechanical Joint Ends - Valve Sizes 18" - 24"

55/MMN/WD
MJxMJ

Component List:

- | | | |
|------------------------|------------------------------|--------------------|
| 217. Bonnet | 228. Gland Flange | 233. Stem Rod |
| 218. Bonnet Gasket | 229. Gland O-Ring | 234. Thrust Collar |
| 219. Body | 230. Upper Stem Seal O-Rings | 237. Wedge |
| 226. Wiper Ring | 231. Stem Seal Bushing | 244. Lifting Eye |
| 227. Gland Flange Bolt | 232. Lower Stem Seal O-Ring | |

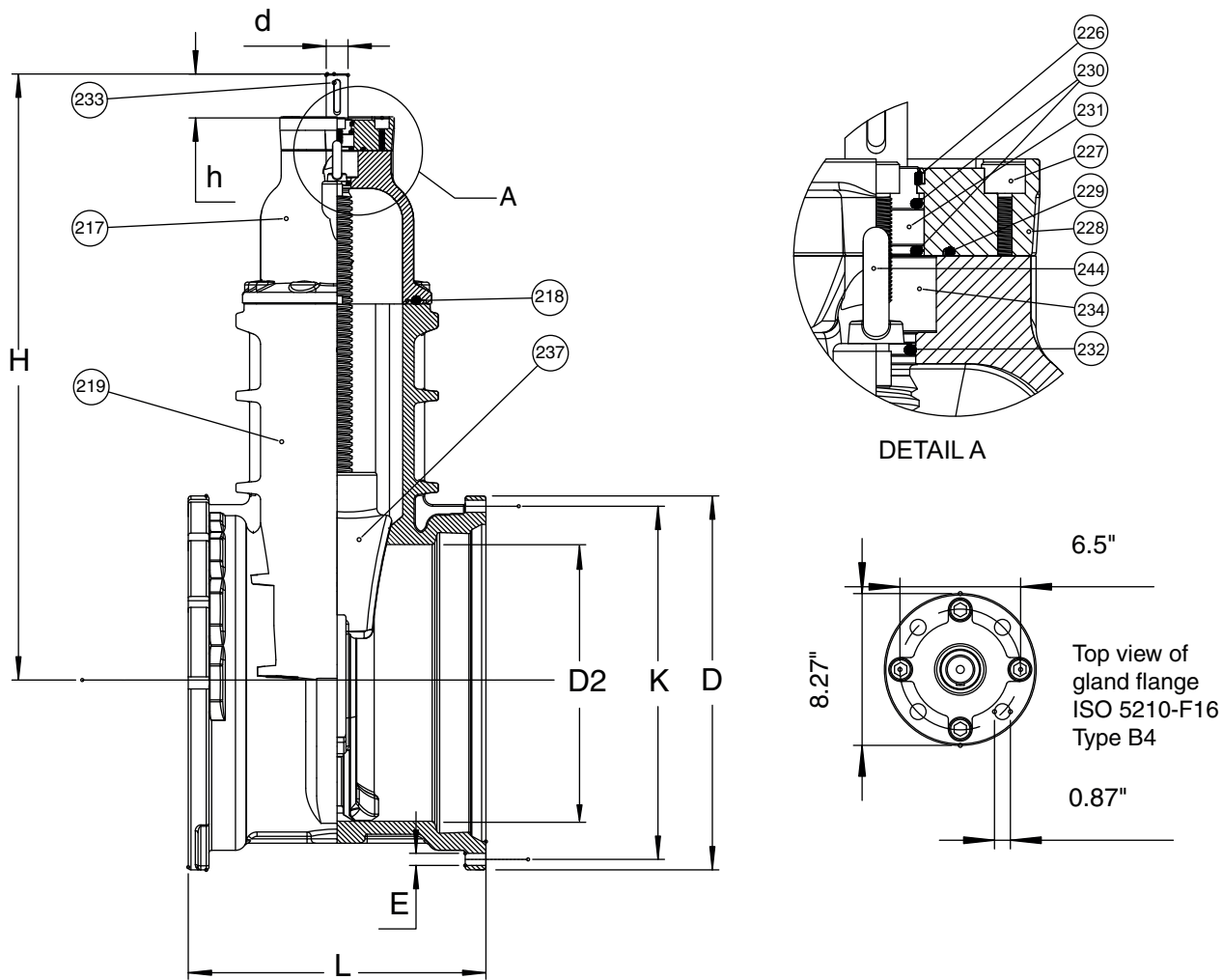

Ref. nos	Size	D	D2	d	E	H	h	K	L	Flange Holes	Turns to open	Wt. Lbs.
55-450-MMN-WD	18"	24.75"	18.00"	1.57"	1.50"	44.50"	3.13"	23.25"	21.00"	12	42	1330
55-500-MMN-WD	20"	27.00"	20.00"	1.57"	1.63"	44.50"	3.13"	25.50"	21.50"	14	42	1400
55-600-MMN-WD	24"	31.50"	24.00"	1.57"	1.88"	51.50"	3.13"	30.00"	23.50"	16	51	1867

