

# AMERICAN AVK RESILIENT SEATED GATE VALVE

250 PSI, Tested to AWWA C509/C515 (NRS)

Mechanical Joint by Flanged Ends to ASME B16.42 Class 150 - Valve Sizes 18" - 24"

55/MFN/WD

MJxFL

### Use:

For water and neutral liquids to maximum 160°F.

### Tests:

Hydraulic test to AWWA C509/C515:

Shell Test: 500 PSI

Seat Test: 250 PSI

Operating Torque Test

### Options:

Stem	Low Zinc Bronze
Thrust Collar	Stainless steel
Wedge	Ductile iron ASTM A536 encapsulated with NBR-rubber compound

### Approvals:

Certified to: NSF/ANSI/CAN 61, NSF/ANSI/CAN 372



Certified to  
NSF/ANSI/CAN 61  
& 372

### Standard Materials:

Body, Bonnet, Gland Flange, Wrench Nut	Ductile iron ASTM A536 (Wrench Nut-painted black for open left, red for open right)
Wedge	Ductile iron ASTM A536 encapsulated with EPDM-rubber compound
Stem	430F stainless steel
Radial Bearing, Wedge Shoe	Polyamide
Coating	Electrostatically applied fusion- bonded epoxy-resin Meets or exceeds AWWA C550
Wedge Nut	Copper alloy
Thrust Collar	Aluminum Bronze
Thrust Bearing	Bronze/PTFE composite
Bonnet Bolts, Gland Bolts	Stainless Steel - 316 sealed with hot melt
Bonnet Gasket, Wiper Ring, O-rings	ASTM D2000 Buna "N" nitrile rubber

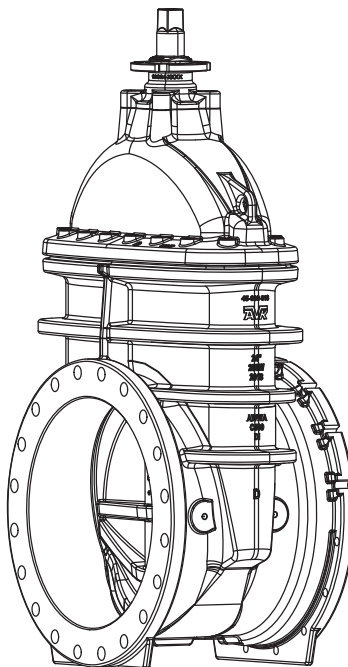

# AMERICAN AVK RESILIENT SEATED GATE VALVE

250 PSI, Tested to AWWA C509/C515 (NRS)

Mechanical Joint by Flanged Ends to ASME B16.42 Class 150 - Valve Sizes 18" - 24"

55/MFN/WD

MJxFL

**Component List:**

- |                      |                              |                             |                      |
|----------------------|------------------------------|-----------------------------|----------------------|
| 216. Bonnet Bolts    | 225. Wrench Nut              | 232. Lower Stem Seal O-Ring | 247. Stem Key        |
| 217. Bonnet          | 226. Wiper Ring              | 233. Stem                   | 250. Wedge Shoe      |
| 218. Bonnet Gasket   | 229. Gland O-ring            | 237. Wedge                  | 274. 18"-24" Bearing |
| 219. Body            | 230. Upper Stem Seal O-Rings | 245. Adaptor Plate Bolts    |                      |
| 220. Wrench Nut Bolt | 231. Stem Seal Bushing       | 246. Adaptor Plate          |                      |

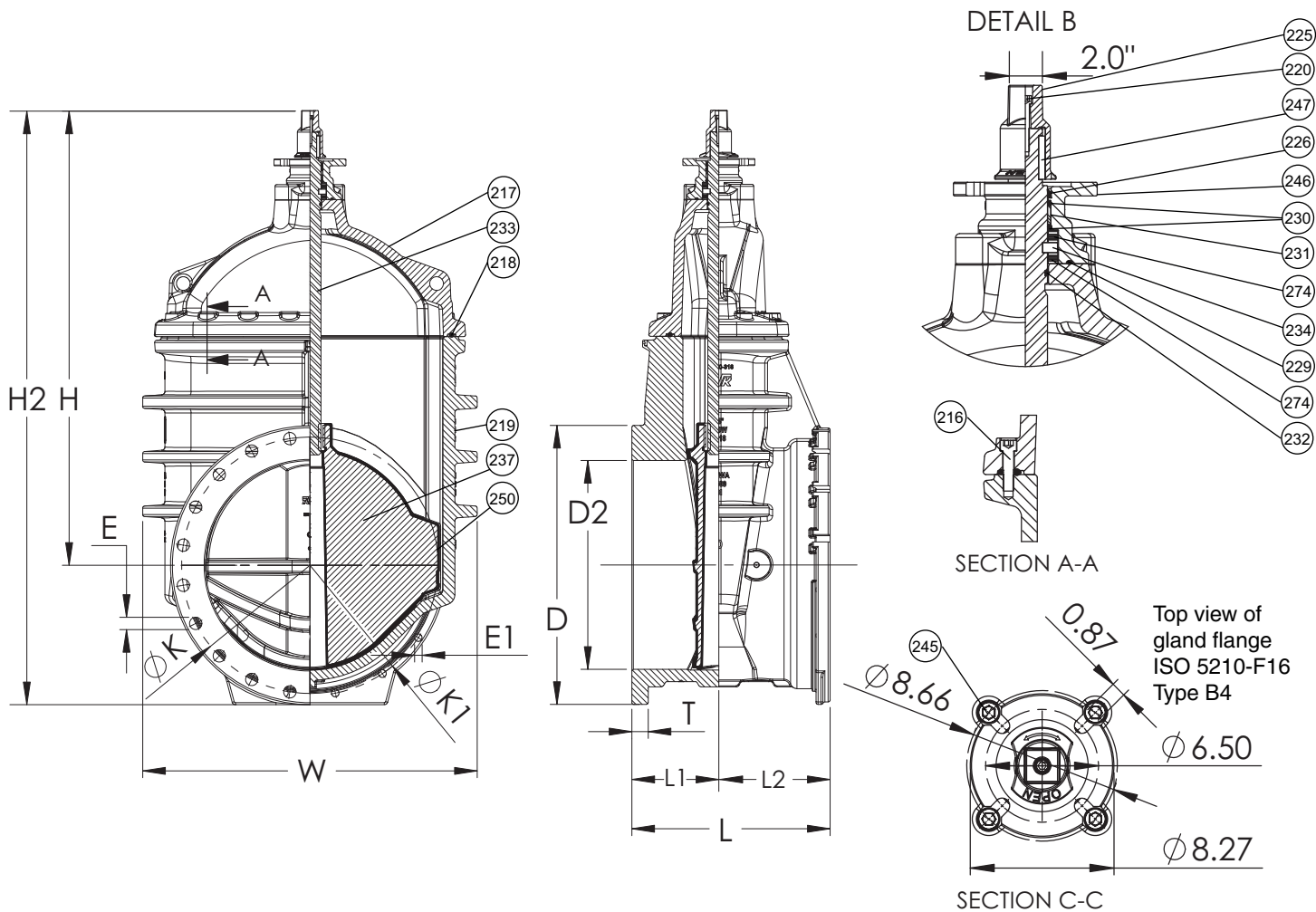

Ref. nos	Size	D	D2	E	E1	H	H2	K	K1	L	L1	L2	T	W	Flange Holes MJ FL	Turns to open	Wt. Lbs.
55-450-MFN-WD	18"	25.00"	18.35"	1.25"	0.88"	46.23"	58.71"	22.75"	23.25"	19.94"	8.50"	11.44"	1.56"	32.95"	12 16	41	1435
55-500-MFN-WD	20"	27.56"	20.31"	1.25"	0.88"	47.38"	61.15"	25.00"	25.50"	20.75"	9.00"	11.75"	1.70"	33.27"	14 20	45	1582
55-600-MFN-WD	24"	32.00"	24.00"	1.38"	0.88"	52.58"	68.65"	29.50"	30.00"	22.80"	10.00"	12.80"	1.87"	38.46"	16 20	53	2145

