

AMERICAN AVK RESILIENT SEATED GATE VALVE
250 PSI, Tested to AWWA C509/C515 (NRS)
Flange Ends to ASME B16.42 Class 150 - Valve Sizes 18" - 24"

55/FFN/WD
FLxFL

Use:

For water and neutral liquids to maximum 160°F.

Tests:

Hydraulic test to AWWA C509/C515:

Shell Test: 500 PSI

Seat Test: 250 PSI

Operating Torque Test

Options:

Stem	Low Zinc Bronze
Thrust Collar	Stainless steel
Wedge	Ductile iron ASTM A536 encapsulated with NBR-rubber compound

Approvals:

Certified to: NSF/ANSI/CAN 61, NSF/ANSI/CAN 372



Certified to
NSF/ANSI/CAN 61
& 372

Standard Materials:

Body, Bonnet, Gland Flange, Wrench Nut	Ductile iron ASTM A536 (Wrench Nut-painted black for open left, red for open right)
Wedge	Ductile iron ASTM A536 encapsulated with EPDM-rubber compound
Stem	430F stainless steel
Radial Bearing, Wedge Shoe	Polyamide
Coating	Electrostatically applied fusion- bonded epoxy-resin Meets or exceeds AWWA C550
Wedge Nut	Copper alloy
Thrust Collar	Aluminum Bronze
Thrust Bearing	Bronze/PTFE composite
Bonnet Bolts, Gland Bolts	Stainless Steel - 316 sealed with hot melt
Bonnet Gasket, Wiper Ring, O-rings	ASTM D2000 Buna "N" nitrile rubber

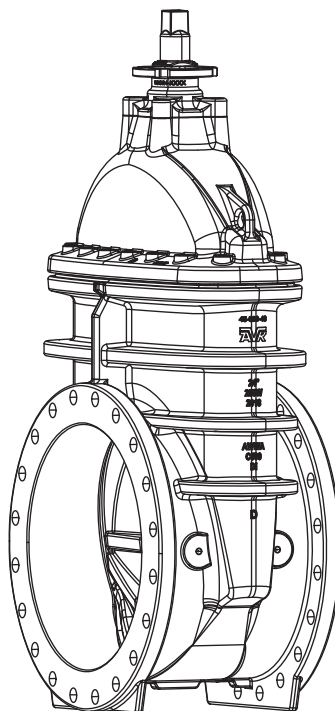

AMERICAN AVK RESILIENT SEATED GATE VALVE
250 PSI, Tested to AWWA C509/C515 (NRS)
Flange Ends to ASME B16.42 Class 150 - Valve Sizes 18" - 24"

55/FFN/WD
FLxFL

Component List:

216. Bonnet Bolts	225. Wrench Nut	232. Lower Stem Seal O-Ring	247. Stem Key
217. Bonnet	226. Wiper Ring	233. Stem	250. Wedge Shoe
218. Bonnet Gasket	229. Gland O-ring	237. Wedge	274. 18"-24" Bearing
219. Body	230. Upper Stem Seal O-Rings	245. Adaptor Plate Bolts	
220. Wrench Nut Bolt	231. Stem Seal Bushing	246. Adaptor Plate	

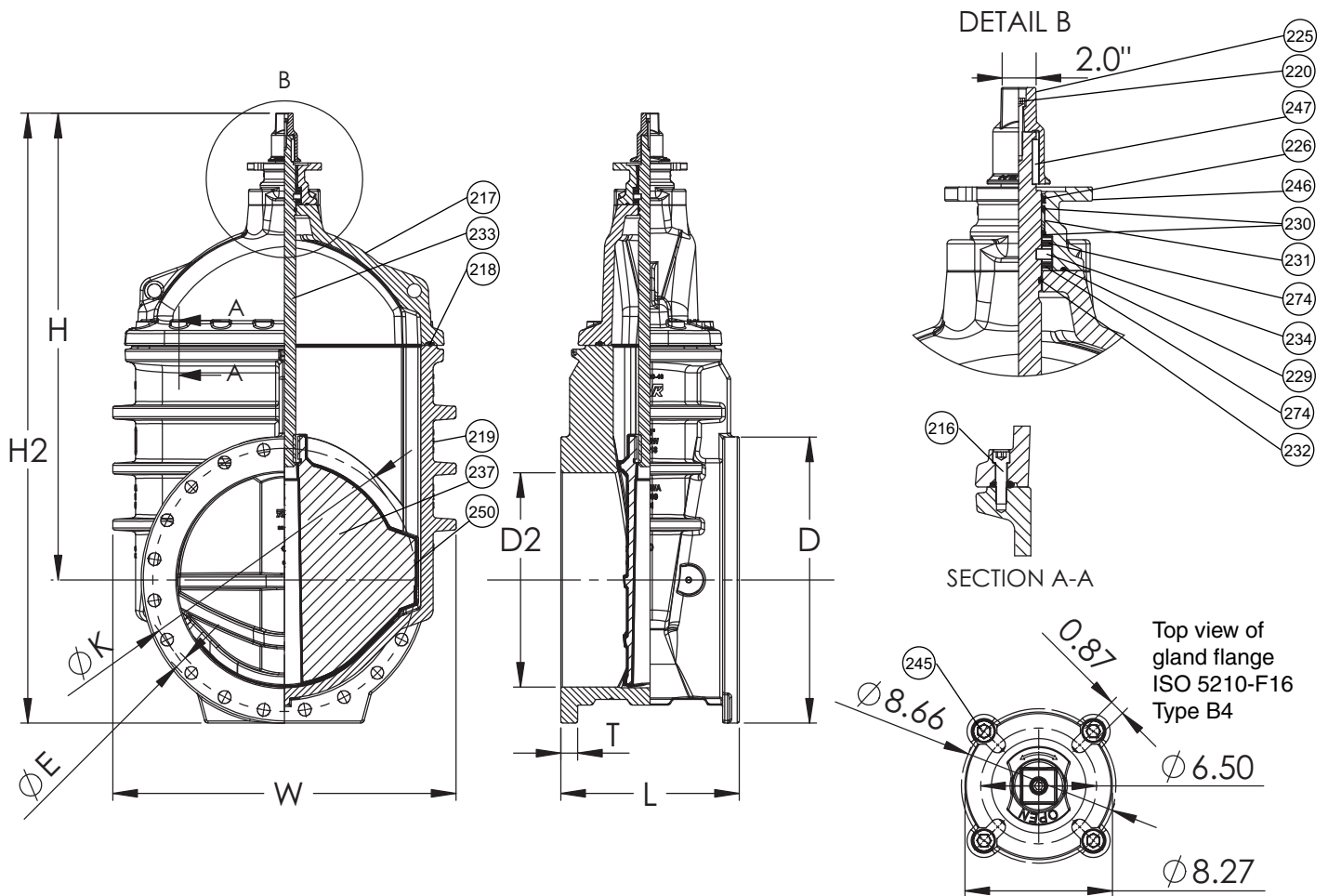

Ref. nos	Size	D	D2	E	H	H2	K	L	T	W	Flange Holes	Turns to open	Wt. Lbs.
55-450-FFN-WD	18"	25.00"	20.00"	1.25"	46.10"	58.58"	22.75"	17.00"	1.56"	32.95"	16	41	1435
55-500-FFN-WD	20"	27.56"	20.00"	1.25"	47.10"	60.87"	25.00"	18.00"	1.70"	33.27"	20	45	1582
55-600-FFN-WD	24"	32.00"	24.00"	1.38"	52.28"	68.35"	29.50"	20.00"	1.90"	38.46"	20	53	2145

