

American AVK Resilient Wedge Gate Valve Class Code/ Ref. # / Breakdown

AA	-	BBB	-	CC	-	D
Series no.		Valve size		Flange config.		Stem type/Option
03 - Small Ductile		032 - 1" *		EE - PExPE		C - Cut-in
18 - Combitee		040 - 1.25" *		FF - FLxFL		F - Fitting
25 - Full Wall Grey Iron		050 - 2"		GG - GRxGR		H - High Pressure
45 - Full Wall Ductile		063 - 2" *		II - IPSxIPS		N - NRS
55 - Large Diameter Ductile		065 - 2.5"		HF - HYxFL		O - OS&Y
65 - Reduced Wall Ductile		070 - 2.5" *		HH - HYxHY		P - PIV
66 - HDPE Ends Ductile		080 - 3"		ME - MJxPE		T - Tapping
		090 - 3" *		MF - MJxFL		
		100 - 4"		MM - MJxMJ		
		150 - 6"		PF - POxFL		
		200 - 8"		PP - POxPO		
		250 - 10"		TT - NPTxNPT		
		300 - 12"				
		350 - 14"				
		400 - 16"				
		450 - 18"				
		500 - 20"				
		600 - 24"				
		800 - 30"				
		900 - 36"				

* For Series 03 only

SERIES 65 AWWA C515

REDUCED WALL DUCTILE

Size	FLxFL	HYxFL	HYxHY	MJxFL	MJxMJ	POxFL	POxPO
2"			X				
2.5"	X*		X				
3"	X	X	X	X	X		
4"	X	X	X	X	X	X	X
6"	X	X	X	X	X	X	X
8"	X	X	X	X	X	X	X
10"	X	X	X	X	X	X	X
12"	X	X	X	X	X	X	X

* Sizes below 3" not included in AWWA Standards

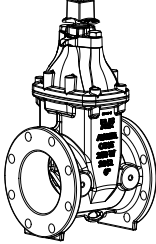
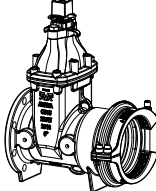
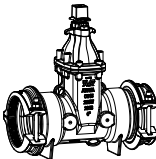
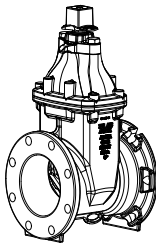
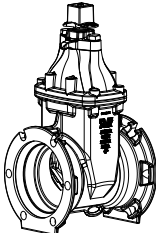
Type	AVK Ref. #	Size	Weight		Price US \$	
			kg	lb		
Series 65/FFN REDUCED WALL DUCTILE FL X FL To AWWA C515 Flanged ends to ASME B 16.42 Class 150 NRS Ductile iron 250 PSI Size 2.5"-12"		65-065-FFN	2.5"	17	38	875
		65-080-FFN	3"	21	46	1,039
		65-100-FFN	4"	28	62	1,161
		65-150-FFN	6"	47	103	1,551
		65-200-FFN	8"	66	146	2,425
		65-250-FFN	10"	102	224	3,851
		65-300-FFN	12"	141	310	4,651
For 2" valves see Series 25 pg#17						
Series 65/HFN REDUCED WALL DUCTILE HY X FL To AWWA C515 HYMAX GRIP® X Flanged end to ANSI B 16.1 Class 125 NRS Ductile iron 250 PSI Size 4"-12"		65-100-HFN	4"	34	73	1,347
		65-150-HFN	6"	54	119	1,811
		65-200-HFN	8"	78	170	2,717
		65-250-HFN	10"	115	253	4,277
		65-300-HFN	12"	151	331	5,357
Series 65/HHN REDUCED WALL DUCTILE HY X HY To AWWA C515 HYMAX GRIP® ends Class 150 NRS Ductile iron 250 PSI Size 1.5"-12"		65-050-HHN	1.5"-2"	38	83	1,068
		65-065-HHN	2.5"	38	83	1,293
		65-080-HHN	3"	38	83	1,436
		65-100-HHN	4"	38	83	1,599
		65-150-HHN	6"	60	131	2,123
		65-200-HHN	8"	88	193	3,329
		65-250-HHN	10"	127	279	4,843
		65-300-HHN	12"	159	349	6,017
		less MJ accessories				
Series 65/MFN REDUCED WALL DUCTILE MJ X FL To AWWA C515 Mechanical joint end X Flanged end to ANSI B 16.1 Class 125 NRS Ductile iron 250 PSI Size 3"-12"		65-080-MFN	3"	19	42	995
		65-100-MFN	4"	25	54	1,119
		65-150-MFN	6"	43	95	1,495
		65-200-MFN	8"	63	139	2,335
		65-250-MFN	10"	90	199	3,709
		65-300-MFN	12"	135	297	4,479
		less MJ accessories				
Series 65/MMN REDUCED WALL DUCTILE MJ X MJ To AWWA C515 To AWWA C515 Mechanical joint ends NRS Ductile iron 250 PSI Size 3"-12"		65-080-MMN	3"	19	42	1,049
		65-100-MMN	4"	24	52	1,171
		65-150-MMN	6"	42	93	1,495
		65-200-MMN	8"	59	129	2,379
		65-250-MMN	10"	89	195	3,709
		65-300-MMN	12"	127	279	4,693
		For 2" valves see Series 25 pg#17				

Type

**Series 65/PFN
REDUCED WALL DUCTILE
PO X FL To AWWA C515**

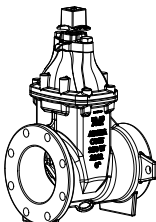

Push-on joint end (TYTON) X
Flanged end to ASME B 16.42
Class 150 NRS
Ductile iron
250 PSI
Size 4"-12"

AVK Ref. #	Size	Weight		Price US \$
		kg	lb	
65-100-PFN	4"	26	58	1,181
65-150-PFN	6"	43	95	1,557
65-200-PFN	8"	65	142	2,459
65-250-PFN	10"	96	212	3,867
65-300-PFN	12"	130	287	4,757

Gaskets not included with DIP PO Valves

**Series 65/PPN
REDUCED WALL DUCTILE
PO X PO To AWWA C515**

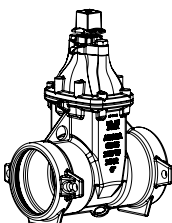

Push-on joint ends (TYTON)
NRS
Ductile iron
250 PSI
Size 4"-12"

65-100-PPN	4"	26	56	1,203
65-150-PPN	6"	43	95	1,583
65-200-PPN	8"	65	142	2,403
65-250-PPN	10"	96	212	3,881
65-300-PPN	12"	130	287	4,865

Gaskets not included with DIP PO Valves

**Series 27/65/67
HYMAX GRIP® Socket Set**



Sizes 1.5"-12"

96-350-00282	1.5" through 12"	260
--------------	------------------	-----

Socket sets can be used on all HYMAX GRIP® fittings for Series 65 valves, Series 27 & 67 hydrants