

AMERICAN AVK RESILIENT SEATED DUCTILE IRON GATE VALVE
250 PSI, Tested to AWWA C509 / C515 (NRS) CWP Tested to 350 PSI
Flanged x Flanged Ends to ASME B16.42 Class 300 - Valve Sizes 4" - 12"
Laylength to ASME B16.10

45/FFH-UL
FLxFL

Use:

For water and neutral liquids to maximum 160°F.

Tests:

Hydraulic test to AWWA C509:

Shell Test: 500 PSI

Seat Test: 250 PSI

Hydraulic test CWP (Cold Working Pressure):

Shell Test: 700 PSI

Seat Test: 350 PSI

Operating Torque Test

Optional Materials:

Stem For UL, FM, ULC for 3" - 12"
 Low Zinc Bronze ASTM B763

For UL, FM, ULC for 14" - 16"
 Aluminum Bronze ASTM B150/B150M

Anti Friction Washers Polyamide

Wedge Ductile iron ASTM A536
 encapsulated with NBR-rubber
 compound

Standard Materials:

Body, Bonnet, Gland Flange, Wrench Nut Ductile iron ASTM A536
 (Wrench Nut-painted black for open left, red for open right)

Coating Electrostatically applied fusion-bonded epoxy-resin
 Meets or exceeds AWWA C550

Stem Standard: Stainless steel - 304

Wedge Ductile iron ASTM A536
 encapsulated with EPDM-rubber
 compound

Wedge Nut, Thrust Collar Bronze

Bonnet Bolts Stainless Steel - 316 sealed with hot melt

Gland Bolts Stainless Steel - 316
 Hexagon bolt

Bonnet Gasket, Wiper Ring, O-Ring Stem Seals, O-Ring Gland Seal
 ASTM D2000 Buna "N" nitrile rubber

Approvals:



*UL/ULC Listed
 *FM Approved
 Certified to: ANSI/NSF 61, ANSI/NSF 372

Certified to NSF/ANSI 61

Certified to NSF/ANSI 372

* Approved at 250 PSI working pressure, 3"-12"
 * Approved at 200 PSI working pressure, 14"-16"

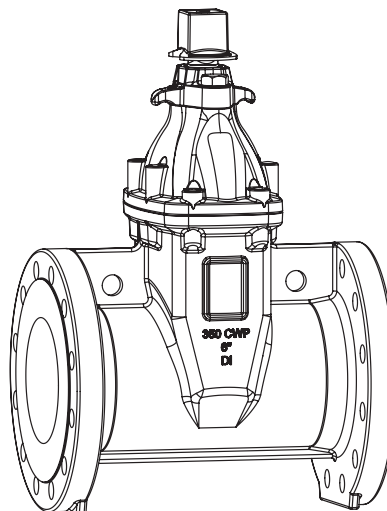

AMERICAN AVK RESILIENT SEATED DUCTILE IRON GATE VALVE
250 PSI, Tested to AWWA C509 / C515 (NRS) CWP Tested to 350 PSI
Flanged x Flanged Ends to ASME B16.42 Class 300 - Valve Sizes 4" - 12"
Laylength to ASME B16.10

45/FFH-UL
FLxFL

Component List:

217. Bonnet	227. Gland Flange Bolt	232. Lower Stem Seal O-Ring
218. Bonnet Gasket	228. Gland Flange	233. NRS Stem
219. Body	229. Gland O-Ring	234. Thrust Collar
225. Wrench Nut	230. Upper Stem Seal O-Rings	237. Wedge
226. Wiper Ring	231. Stem Seal Bushing	

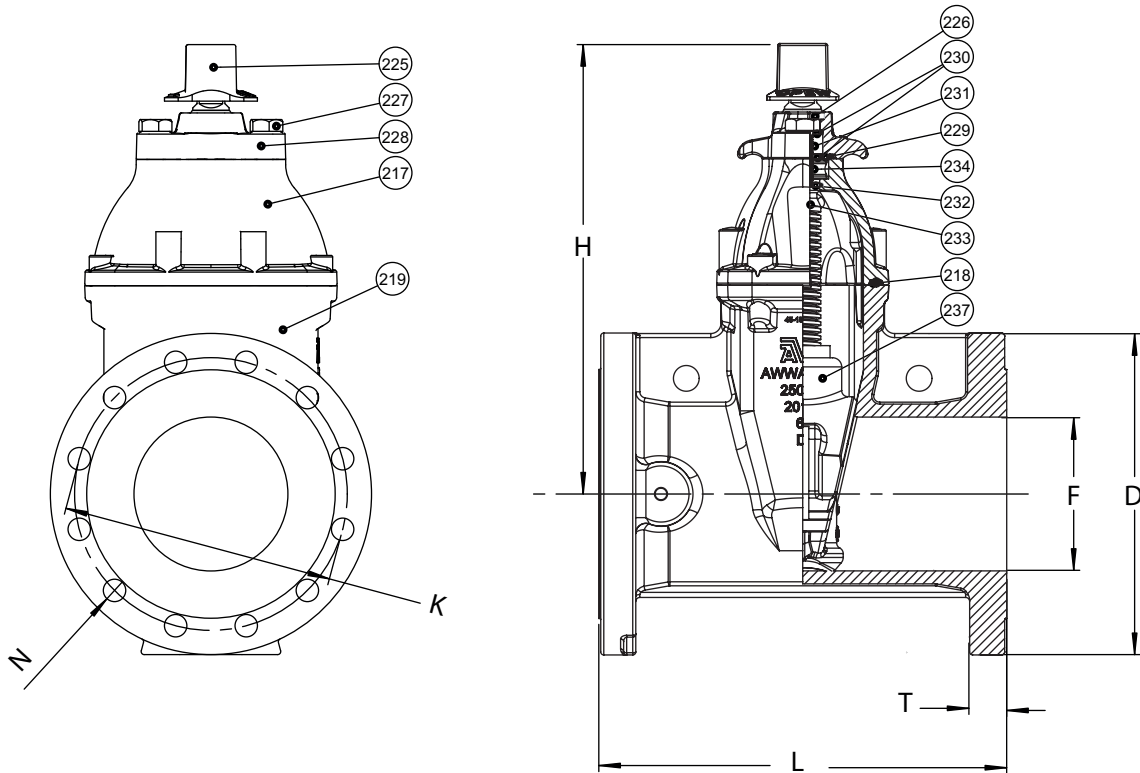

RefNo.	Size	D	F	H	K	L	N	T	Flange Holes	Turns to Open	Weight Lbs.
45-100-FFH	4"	10.00"	4.00"	13.50"	7.88"	12.00"	0.88"	1.25"	8	14	91
45-150-FFH	6"	12.50"	6.00"	17.50"	10.63"	15.88"	0.88"	1.44"	12	21	161
45-200-FFH	8"	15.00"	8.00"	21.50"	13.00"	16.50"	1.00"	1.62"	12	26	244
45-250-FFH	10"	17.50"	10.00"	24.75"	15.25"	18.00"	1.12"	1.88"	16	32	366
45-300-FFH	12"	20.50"	12.00"	27.75"	17.75"	19.76"	1.25"	2.00"	16	38	541

