

AMERICAN AVK RESILIENT SEATED GATE VALVE, 250 PSI

66/EEN

Meets AWWA C515 where applicable (NRS)

PExPE

- DIPS & IPS Polyethylene Pipe Ends - Valve Sizes 2" through 12"

Use:

For water and neutral liquids to maximum 160°F.

Tests:

Hydraulic test to AWWA C515:

Shell Test: 500 PSI

Seat Test: 250 PSI

Operating Torque Test

Optional Materials:

Stem Bronze

Anti Friction Washers Polyamide - W/ Bronze stem only

Pipe 2"- 3"
SDR 9, SDR 11, SDR 13.5, SDR 17
4"-12"
SDR 9, SDR 11, SDR 13.5
DIPS or IPS. Suitable for butt fusion
or electro fusion joining. Pipe stubs
to AWWA C906.

**Specify IPS or DIPS, and
SDR when placing order.**

Standard Materials:

Body, Gland Flange Ductile iron ASTM A536
Bonnet

Coating Electrostatically applied fusion-
bonded epoxy-resin, holiday free
internally

Wrench Nut Ductile iron ASTM A536
- painted black for open left,
red for open right.

Stem Standard: Stainless steel ASTM A582

Wedge Ductile iron ASTM A536 encapsulated
with EPDM-rubber compound

Wedge Nut,
Thrust Collar Bronze

Bolts Stainless Steel -316 sealed with
hot melt

Bonnet Gasket,
Wiper Ring,
O-Ring Stem Seals,
O-Ring Gland Seal ASTM D2000 Buna "N" nitrile
rubber

Pipe PE 3408 or PE 4710. Suitable for butt
fusion or electro fusion joining. Pipe
stubs to AWWA C906

Approvals:

Certified to: NSF/ANSI/CAN 61, NSF/ANSI/CAN 372

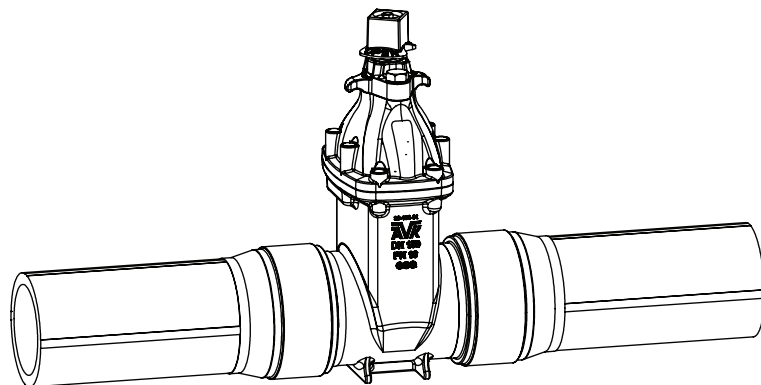

AMERICAN AVK RESILIENT SEATED GATE VALVE, 250 PSI
Meets AWWA C515 where applicable (NRS)
- DIPS & IPS Polyethylene Pipe Ends - Valve Sizes 2" through 12"

66/EEN
PEXPE

Component List:

- | | | |
|--------------------|------------------------------|-----------------------------|
| 217. Bonnet | 227. Gland Flange Bolt | 232. Lower Stem Seal O-Ring |
| 218. Bonnet Gasket | 228. Gland Flange | 233. NRS Stem |
| 219. Body | 229. Gland O-Ring | 234. Thrust Collar |
| 225. Wrench Nut | 230. Upper Stem Seal O-Rings | 237. Wedge |
| 226. Wiper Ring | 231. Stem Seal Bushing | |

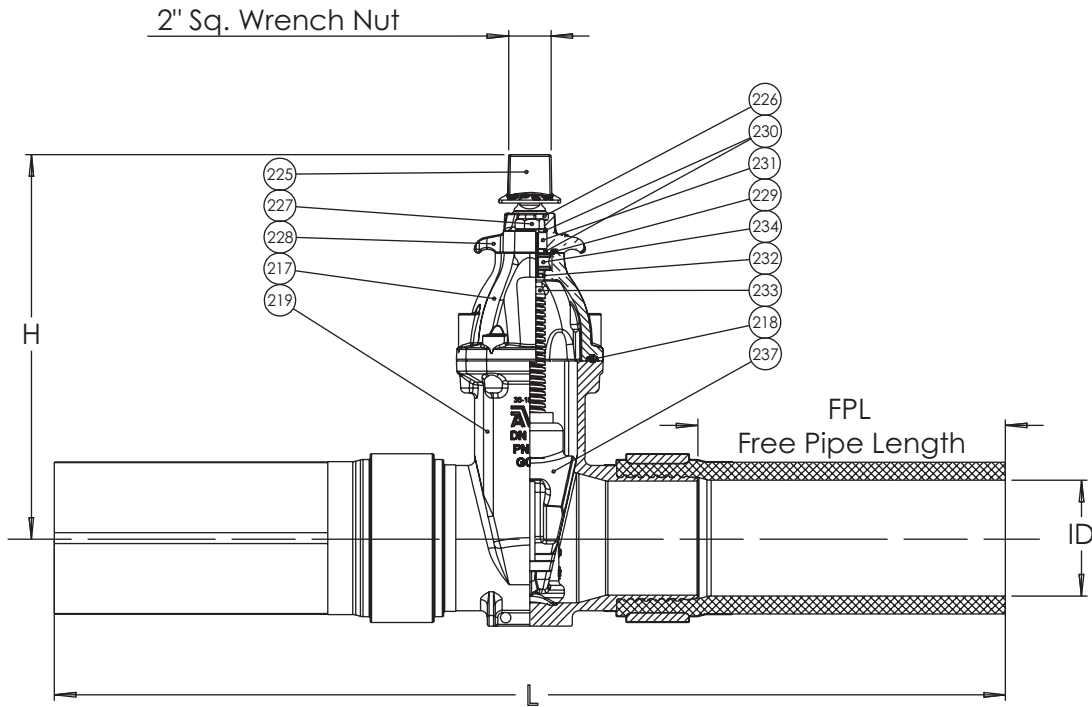

Ref. nos.	Size	H	L	FPL Free Pipe Length	Turns to open	Wt. Lbs.
66-050-EEN	2"	10.50"	19.50"	5.10"	11	20
66-080-EEN	3"	12.09"	19.75"	5.20"	12	36
66-100-EEN	4"	13.50"	41.93"	14.92"	14	56
66-150-EEN	6"	17.50"	43.35"	14.00"	21	114
66-200-EEN	8"	21.50"	44.06"	13.04"	26	175
66-250-EEN	10"	24.75"	44.96"	11.25"	32	227
66-300-EEN	12"	27.63"	47.09"	11.14"	38	335

ID*: Refer to Pipe Manufacturers reference tables

