

AMERICAN AVK RESILIENT SEATED DUCTILE IRON GATE VALVE
250 PSI, Tested to AWWA C509 (NRS)
Push-on ends for IPS PVC Pipe-2"

03/IIN
PO

Use:

For water and neutral liquids to maximum 160°F.

Tests:

Hydraulic test to AWWA C509:

Shell Test: 500 PSI

Seat Test: 250 PSI

Operating Torque Test

Optional Materials:

Bonnet Bolts Option a): Stainless Steel - 316
 sealed with hot melt

Approvals:

Certified to:
 NSF/ANSI 61
 NSF/ANSI 372



Standard Materials:

Body, Bonnet, Gland Flange, Wrench Nut	Ductile iron ASTM A536 (Wrench Nut-painted black for open left, red for open right)
Coating	Electrostatically applied fusion- bonded epoxy-resin Meets or exceeds AWWA C550
Stem	Standard: Stainless steel ASTM A582
Wedge	Brass - encapsulated with EPDM-rubber compound
Bonnet Bolts	Stainless Steel - 304 sealed with hot melt
Gland Bolts	Stainless Steel - 304 Hexagon bolt
Bonnet Gasket, Wiper Ring, O-Ring Stem Seals	ASTM D2000 Buna "N" nitrile rubber
Stem Collar	Brass
Stem Seal	Polyamide
Cap Screw Bushing	Zinc coated steel
Pipe Seal	SBR with plastic insert
Pipe Guide	Plastic

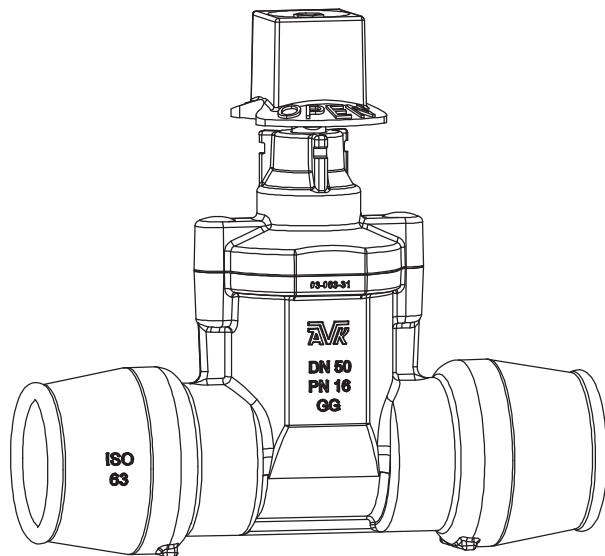

AMERICAN AVK RESILIENT SEATED DUCTILE IRON GATE VALVE

03/IIN

250 PSI, Tested to AWWA C509 (NRS)

PO

Push-on ends for IPS PVC Pipe-2"

Component List:

- 216. Bonnet Bolt
- 217. Bonnet
- 218. Bonnet Gasket
- 219. Body
- 225. Wrench Nut
- 226. Wiper Ring
- 233. Stem
- 237. Wedge
- 238. Outer O-rings
- 239. Inner O-rings
- 240. Slide Bearing
- 241. Stem Collar
- 242. Stem Seal

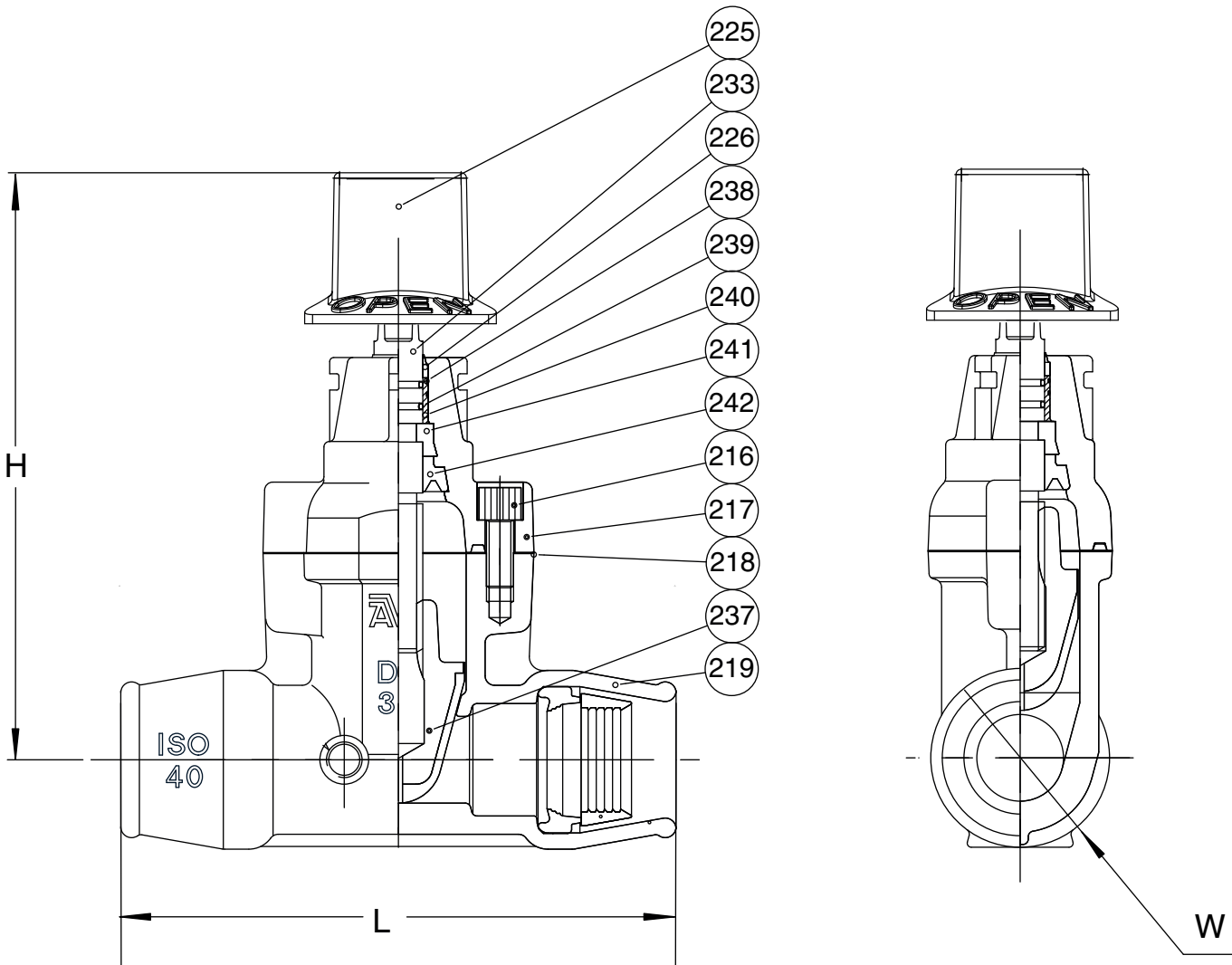

Ref. nos.	Size	H	L	W	Turns to Open	Wt. Lbs.
03-063-IIN	2"	10.50"	12.04"	3.90"	13	18

