

AVK RESILIENT SEATED GATE VALVES



EXPECT
RELIABILITY



AVK VALVES STANDARD FEATURES

AVK STANDARD FEATURES

- AVK Gate Valves are made of ductile iron and meet or exceed AWWA C509 or C515
- High strength ASTM A582 stainless steel stems standard
- Cold-rolled threading process eliminates bent or broken stems
- 316 stainless steel bonnet bolts are fully isolated against corrosion to eliminate bonnet bolt failures
- Certified to comply with NSF 61, NSF 372 and the new low-lead requirements of the Safe Drinking Water Act
- All AVK Gate Valves are covered by a 10 year warranty
- Made in the USA

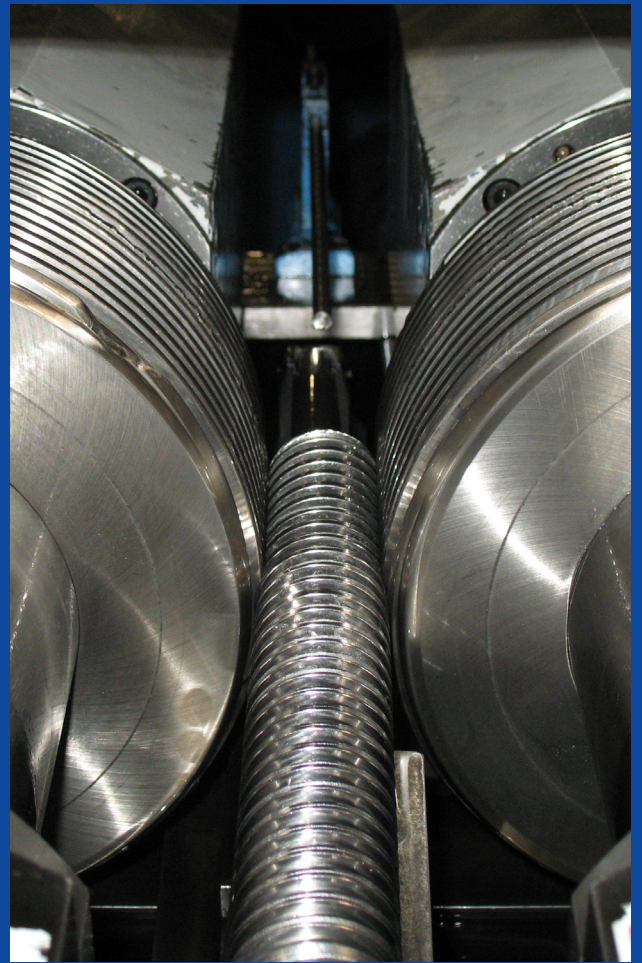

FULLY ENCAPSULATED EPDM WEDGE DUCTILE IRON CORE

- Fully encapsulated EPDM wedge prevents deterioration from disinfectants
- Fixed wedge-nut provides higher torque resistance and prevents rubber wear and leakage



SERIAL NUMBER – PERMANENTLY ENGRAVED ON STEM

- Every AVK valve has a unique serial number engraved on the stem
- Serial numbers provide complete traceability to the date the valve was built and every operation performed throughout our manufacturing process.



EXPECT SUPERIOR DESIGN



SERIES 03 SMALL DIAMETER GATE VALVES

- NPT threaded ends, 1"-3" ; also available in 2" push-on
- Meets or exceeds applicable requirements of AWWA C509 and C515

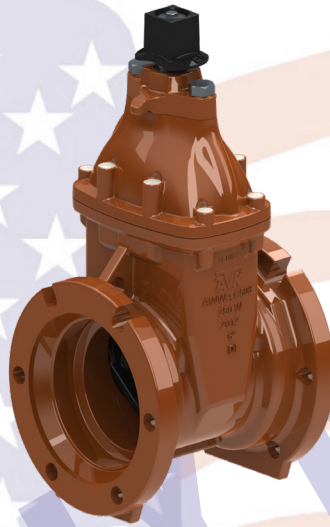

SERIES 45 FULL WALL DUCTILE IRON GATE VALVES

- Full wall, ductile iron – meets or exceeds both AWWA C515 and C509, available in sizes 2.5"-16"
- Available in all end configurations, including grooved ends, tapping valves, and OS&Y

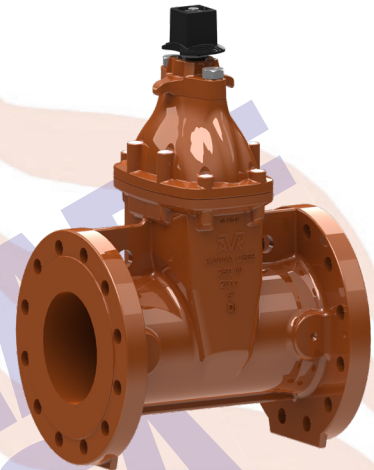

SERIES 45 HIGH PRESSURE GATE VALVES

- Cold Working Pressure 350 PSI (CWP)
- Ductile iron, available in sizes 4"-12" ASME Class 250 flanges

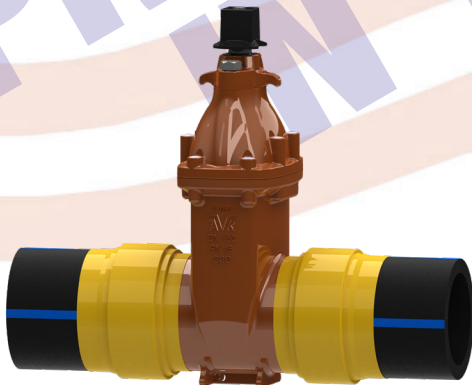

SERIES 66 FUSIBLE HDPE GATE VALVES

- Designed for use with HDPE water distribution systems
- Leak-proof, fusible joints – stronger than the pipe itself – for a leak-free distribution system
- Saves labor hours, with no need for mechanical flanges or stiffening inserts
- Ductile iron bodies, available in sizes 2"-12"
- 14" and 16" available upon request

POLYURETHANE (PUR) COATING

- Industry's strongest, corrosion-resistant, exterior coating
- For use in highly corrosive soils – available on any AVK valve or hydrant
- 60 mil thickness, for toughness and durability



EXPECT SOLUTIONS

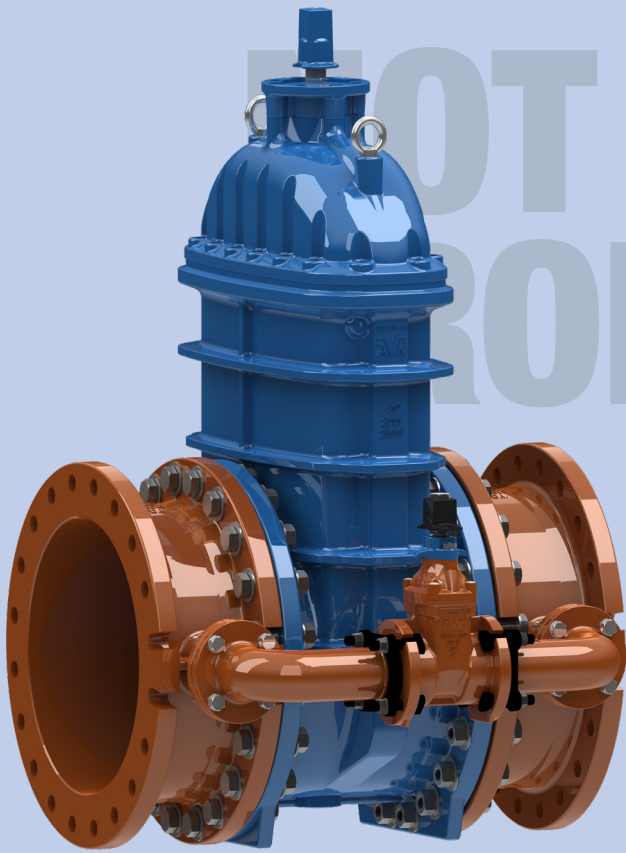

SERIES 55 LARGE DIAMETER GATE VALVE

- Series 55 large diameter gate valves available in sizes 18"-36"
- All valves come pre-fitted with a mounting plate to mount gearing or motorized actuators; Bevel or spur gearing is available Bypass assemblies available ductile iron that meet or exceed AWWA C515

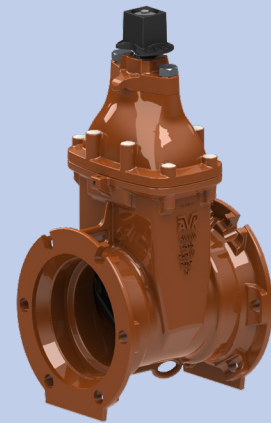

SERIES 65 REDUCED WALL DUCTILE GATE VALVES

- Rated working pressure 250 PSI
- AWWA C515 ductile iron, sizes 2.5"-12"

GATE VALVES FOR RECLAIMED WATER

- All AVK gate valves are available for reclaimed water applications

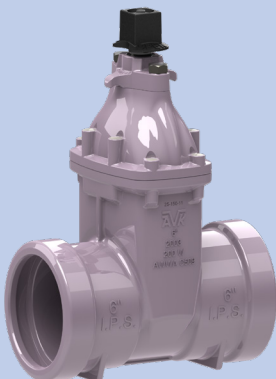

GATE VALVES FOR FIRE PROTECTION

- Full wall, ductile iron – meet or exceed both AWWA C515 and C509
- Available in all configurations, including grooved ends and OS&Y

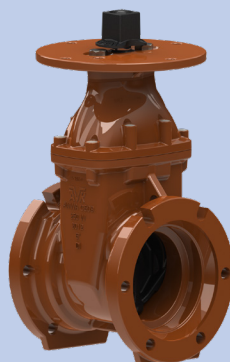

RESILIENT SEATED

SERIES 65 GATE VALVES AWWA C515

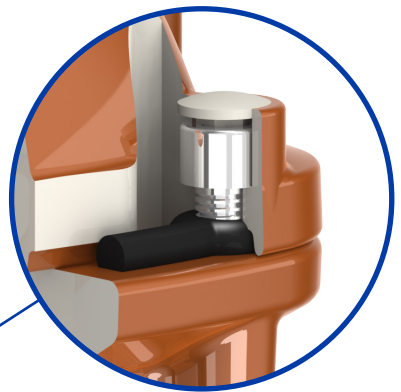
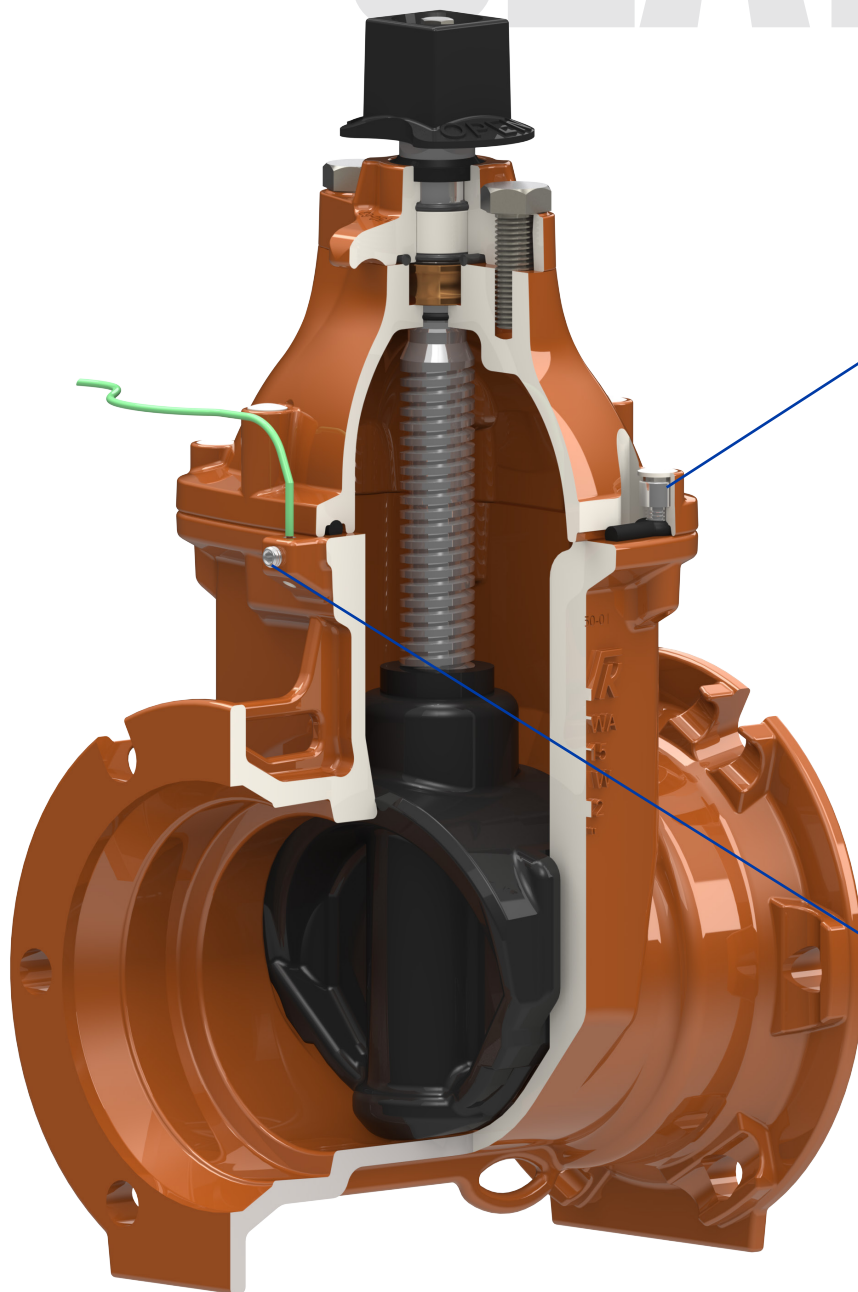

AVK BOLTING AND GASKET SYSTEM

- 316 stainless steel bolts
- Fully isolated and protected against corrosion – bonnet bolts never come in contact with water or soil
- Countersunk and capped with hot-melt
- Easily disassembled after years of service – but, you'll never need to...

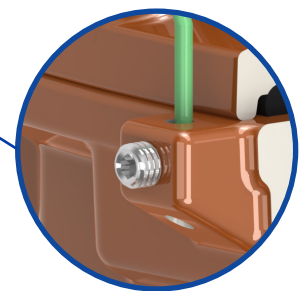

AVK ANODE GROUNDING LUG

- Provides corrosion resistance in actively corrosive soil environments
- Available on Series 65 valves with MJ and Push-on pipe connections



American AVK Company Locations

American AVK Company

2155 Meridian Blvd.
Minden, NV
89423
USA

Tel.: 775-552-1400
Fax.: 775-783-1031
sales@avkus.com
www.americanavk.com

F99002/01-27-2022
Copyright©AVK Group A/S 2022

