

**AMERICAN AVK RESILIENT SEATED DUCTILE IRON GATE VALVE
FOR FIRE PROTECTION, 250 PSI rated working pressure (NRS)
IPS Grooved End according to AWWA C606 x Flanged - Valve sizes 2.5" - 8"**

**145/GFN
GRxFL**

Use:
For water to maximum 160°F.

Tests:
Hydraulic tests:
Shell Test: 500 PSI
Seat Test: 375 PSI
Operating Torque Test

Optional Materials:

Handwheel	Ductile iron ASTM A536
Bonnet Bolts	Stainless Steel - 304 sealed with hot melt Stainless Steel - 316 sealed with hot melt
Gland Bolts	Stainless Steel - 304 Hexagon bolt Stainless Steel - 316 sealed with hot melt
Coating	PUR
Tapping Plug	Specify other than standard

Approvals:

UL/ULC Listed
FM Approved



Standard Materials:

Body, Bonnet, Gland Flange, Wrench Nut	Ductile iron ASTM A536 (Wrench Nut-painted black for open left, red for open right)
Coating	Electrostatically applied fusion-bonded epoxy-resin
Stem	304 stainless steel
Wedge	Ductile iron ASTM A536 encapsulated with EPDM-rubber compound and Nylon Wedge Shoes
Wedge Nut, Thrust Collar	Bronze
Wedge Shoe	Nylon
Bonnet Bolts	Zinc plated steel, sealed with hot melt
Gland Bolts	Zinc plated steel
Tapping Plug	Zinc plated steel - Left hand side facing AVK logo (standard)
Bonnet Gasket, Wiper Ring, O-Ring Stem Seals, O-Ring Gland Seal	NBR

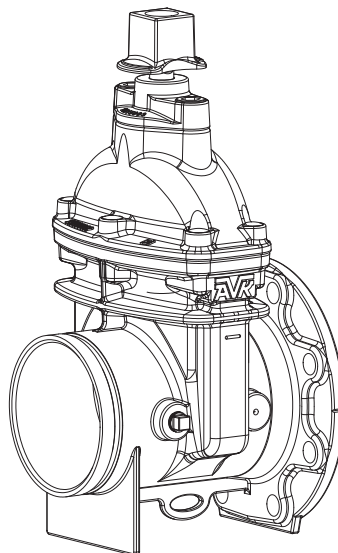

**AMERICAN AVK RESILIENT SEATED DUCTILE IRON GATE VALVE
FOR FIRE PROTECTION, 250 PSI rated working pressure (NRS)
IPS Grooved End according to AWWA C606 x Flanged - Valve sizes 2.5" - 8"**

**145/GFN
GRxFL**

Component List:

- | | | |
|------------------------|------------------------------|--------------------|
| 217. Bonnet | 228. Gland Flange | 233. NRS Stem |
| 218. Bonnet Gasket | 229. Gland O-Ring | 234. Thrust Collar |
| 219. Body | 230. Upper Stem Seal O-Rings | 237. Wedge |
| 225. Wrench Nut | 231. Stem Seal Bushing | 250. Wedge Shoe |
| 227. Gland Flange Bolt | 232. Lower Stem Seal O-Ring | |

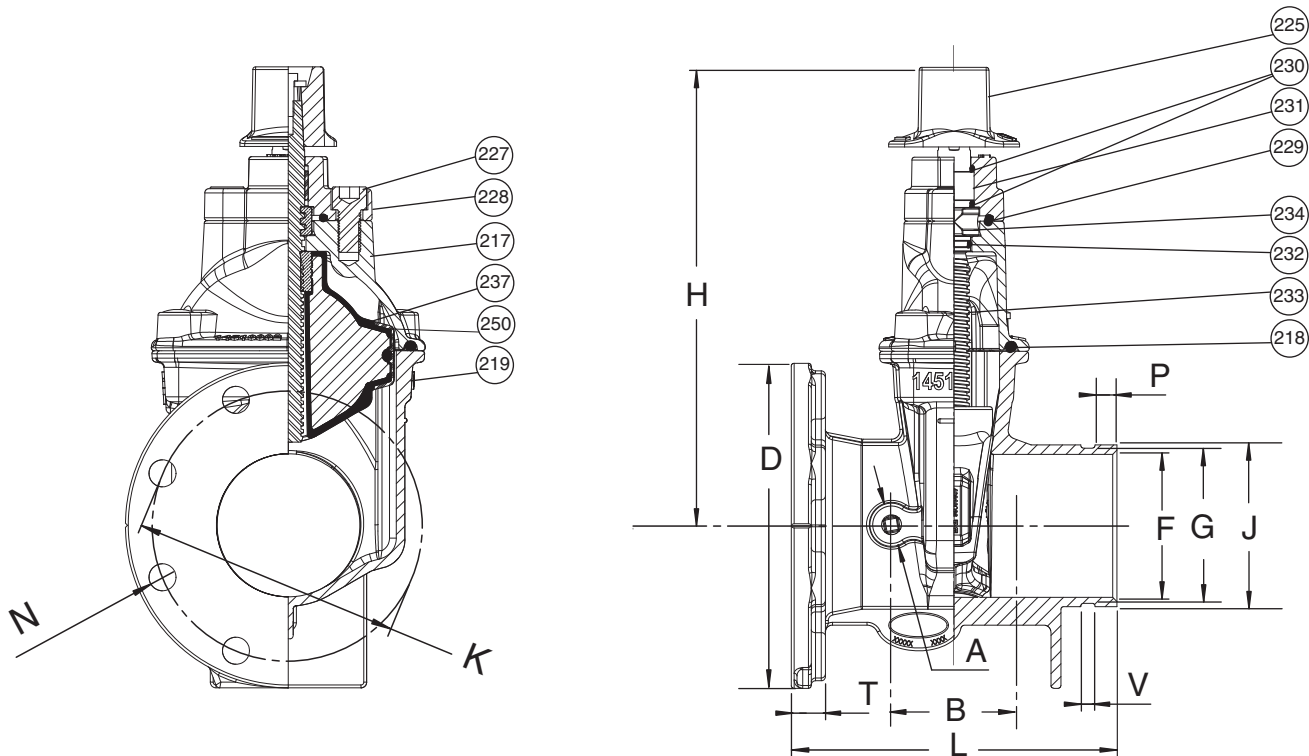

Ref No.	Size	A	B	D	F	G	H	J	K	L	N	P	T	V	Flange Turns to Weight		
															Holes	Open	Lbs.
145-080-GFN	2½"	1.18"	2.83"	7.00"	2.36"	2.70"	10.83"	2.85"	5.50"	7.50"	0.75"	0.62"	0.71"	0.34"	4	19	20
145-080-GFN	3"	1.18"	3.15"	7.50"	3.00"	3.30"	12.06"	3.48"	6.00"	8.00"	0.75"	0.62"	0.79"	0.34"	4	18	29
145-100-GFN	4"	1.18"	3.46"	9.00"	4.00"	4.29"	12.93"	4.48"	7.50"	9.00"	1.00"	0.61"	1.00"	0.39"	8	22	32
145-150-GFN	6"	1.57"	4.09"	11.00"	6.00"	6.42"	16.35"	6.61"	9.50"	10.50"	1.06"	0.61"	1.06"	0.39"	8	27	70
45-200-GFN	8"	1.57"	4.09"	13.50"	8.00"	8.40"	19.94"	8.61"	11.75"	11.50"	1.14"	0.74"	1.14"	0.45"	8	35	154

