

AMERICAN AVK STORZ NOZZLES & ADAPTERS

For Wet & Dry Barrel Hydrants

Tested to AWWA C503 / C502

24/27

STORZ

Use:

For water and neutral liquids to maximum 160°F.

Approvals:

UL,ULC Listed*

FM Approved*



* For 4" & 5" Storz Nozzles only.

Standard Materials:

Nozzle, Adapter	Bronze
Nozzle Cap	Grey Iron, ASTM 126, class B
O-rings	ASTM D2000 Buna "N" nitrile rubber

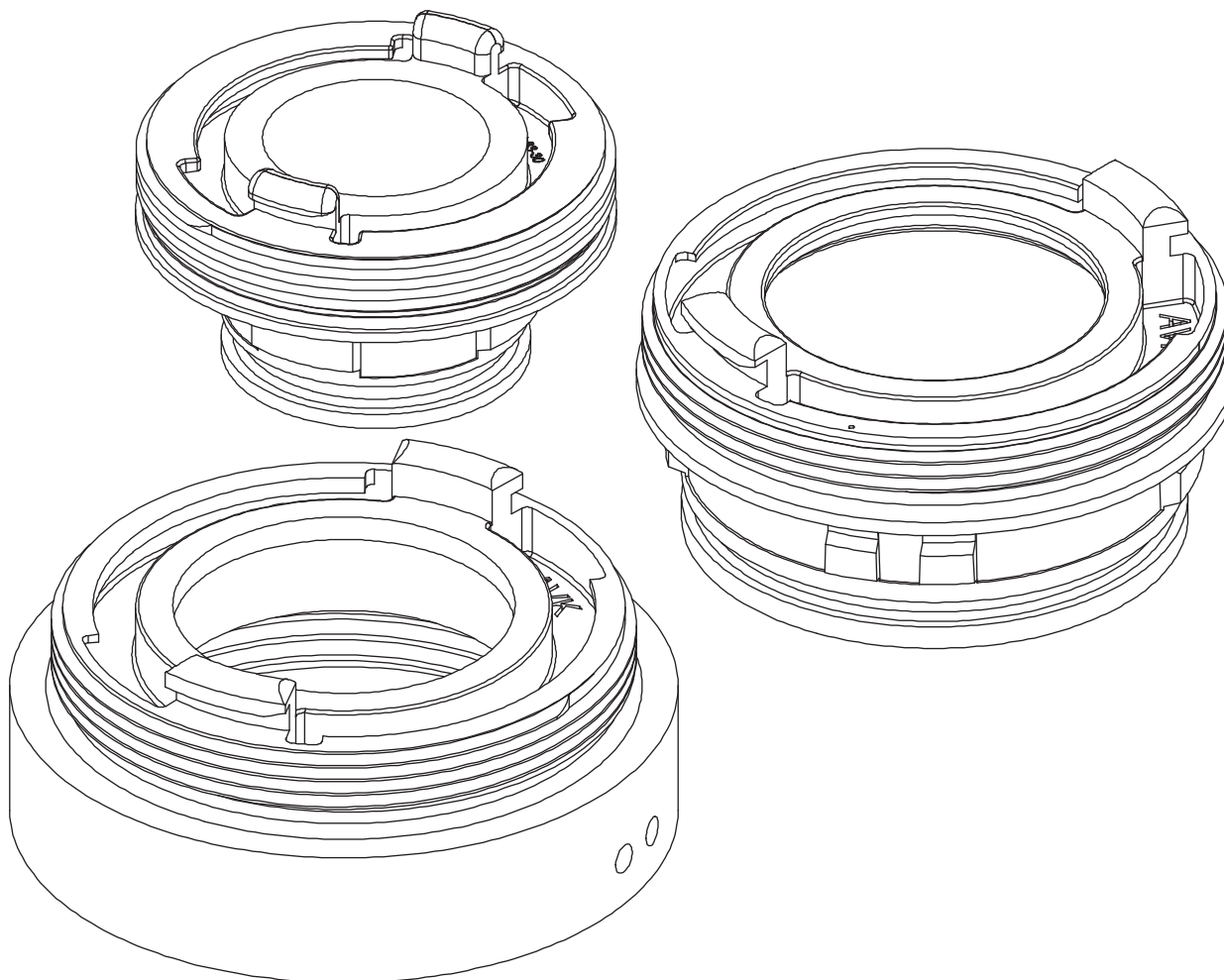

AMERICAN AVK STORZ NOZZLES & ADAPTERS

For Wet & Dry Barrel Hydrants

Tested to AWWA C503 / C502

24/27
STORZ

Component List:

- | | |
|--------------------------|----------------------------|
| 25. Pumper Nozzle O-ring | 92. Inner Storz Cap O-ring |
| 26. Pumper/Storz Nozzle | 93. Storz Adapter |
| 27. Pumper Cap Gasket | |
| 28. Pumper Cap | |
| 73. Storz Cap O-ring | |

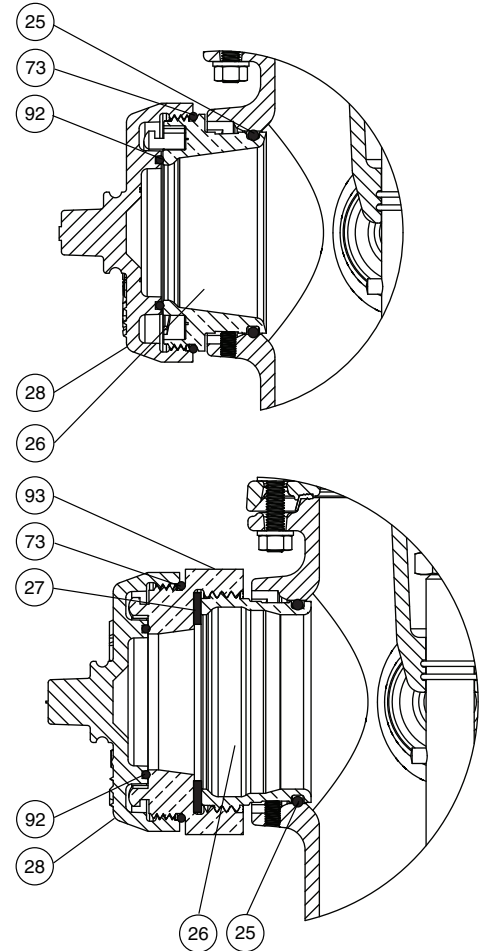
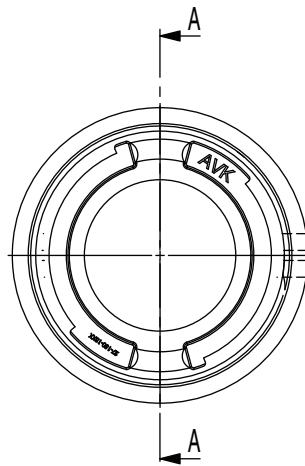
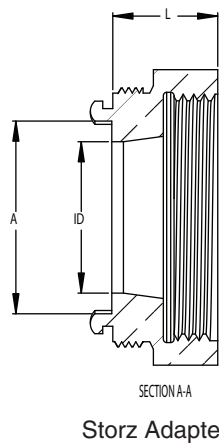
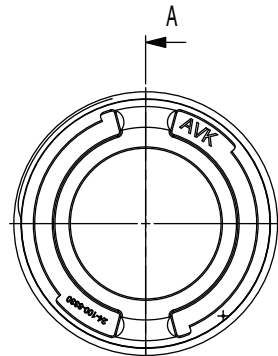
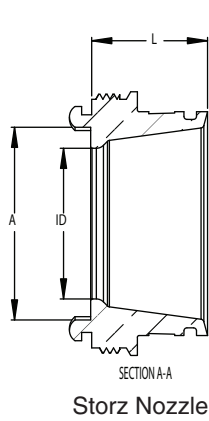

Storz Nozzle

Ref No.	Size	A	ID	L
24/27-075-83-30*	2½"	3.27"	2.28"	2.56"
24/27-100-83-30*	4"	4.53"	3.54"	2.70"
24/27-200-83-30*	5"	5.83"	4.68"	2.89"

* 24- Wet Barrel / 27- Dry Barrel

Storz Adapter

Ref No.	Size	A	ID	L
27-100-13-XX	4" Nozzles to 4" Storz	4.53"	3.54"	2.47"
27-150-13-XX	4½" Nozzles to 4" Storz	4.83"	3.54"	2.47"
27-200-13-XX	4" Nozzles to 5" Storz	5.83"	4.65"	2.40"
27-250-13-XX	4½" Nozzles to 5" Storz	5.83"	4.65"	2.40"

