

AMERICAN AVK STAINLESS STEEL, UL LISTED, WET BARREL HYDRANT

Meets or exceeds AWWA C503 (latest) - Working Pressure - 200 PSI

**24S/PPH
WET STAINLESS**

Use:

For water and neutral liquids to maximum 160°F.

Tests:

Hydraulic test to AWWA C503:

Shell Test: 400 PSI (Two times the 200 PSI
rated working pressure)

Options:

Break Flange

Hydrant Check Valve (FlowGuard II ®)

Storz Nozzles, 2½" through 5"

6, or 8 bolt flange mounting patterns.

Approvals:

UL Listed,
at 200 PSI



Certified to: ANSI/NSF 61, ANSI/NSF 372

Certified to
NSF/ANSI 61

Certified to
NSF/ANSI 372

* Storz aluminum cap, UL/FM, Storz iron cap, non - UL/FM

Standard Materials:

Nozzle Section	Cast 304 stainless steel CF-8 ASTM A351
Caps, Dummy Nuts	Cast iron ASTM A126 class B
Stems, Nozzles, Stem Nuts	Bronze
Valve Discs	Bronze encapsulated with Nitrile Rubber
O-rings,	NBR
Cap Gaskets	Neoprene rubber
Nozzle Retainer Screws Thrust Collars, Thrust Nuts	Stainless Steel
Cap Chains	Zinc Plated Steel
Coating	Electrostatically applied fusion-bonded epoxy- resin

Note: Nozzles, Stem Nuts and Stem Seals field
replaceable

Pumper Nozzles interchangeable from 4" to 5"

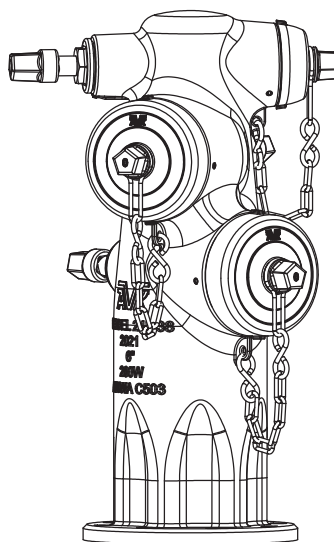

Series 243X-PPH
2 Pumper, 1 Hose Outlet



AMERICAN AVK STAINLESS STEEL, UL LISTED, WET BARREL HYDRANT

Meets or exceeds AWWA C503 (latest) - Working Pressure - 200 PSI

**24S/PPH
WET STAINLESS**

Component List:

- | | | |
|----------------------------|-------------------------------|-----------------------------|
| 19. Hose Nozzle Cap | 111. Inner Stem Nut O-Ring | 134. 2.5" Valve Stem |
| 22. Hose Nozzle O-Ring | 112. Dummy Nut | 135. 2.5" Thrust Nut |
| 23. Nozzle Retaining Screw | 113. Dummy Nut Retaining Bolt | 136. 2.5" Thrust Collar |
| 24. Chain Set | 114. Stem Nut Retaining Screw | 137. 4.5" Valve Disc |
| 25. Pumper Nozzle O-Ring | 115. Hose Nozzle Cap Gasket | 138. 4.5" Valve Stem |
| 28. Pumper Cap | 116. Hose Nozzle | 139. 4.5" Thrust Nut |
| 101. Nozzle Section | 120. Pumper Cap Gasket | 140. 4.5" Thrust Collar |
| 109. Outer Stem Nut O-ring | 126. Pumper Nozzle | 141. 4.5" Thrust Nut O-ring |
| 110. Stem Nut | 133. 2.5" Valve Disc | 142. 2.5" Thrust Nut O-ring |

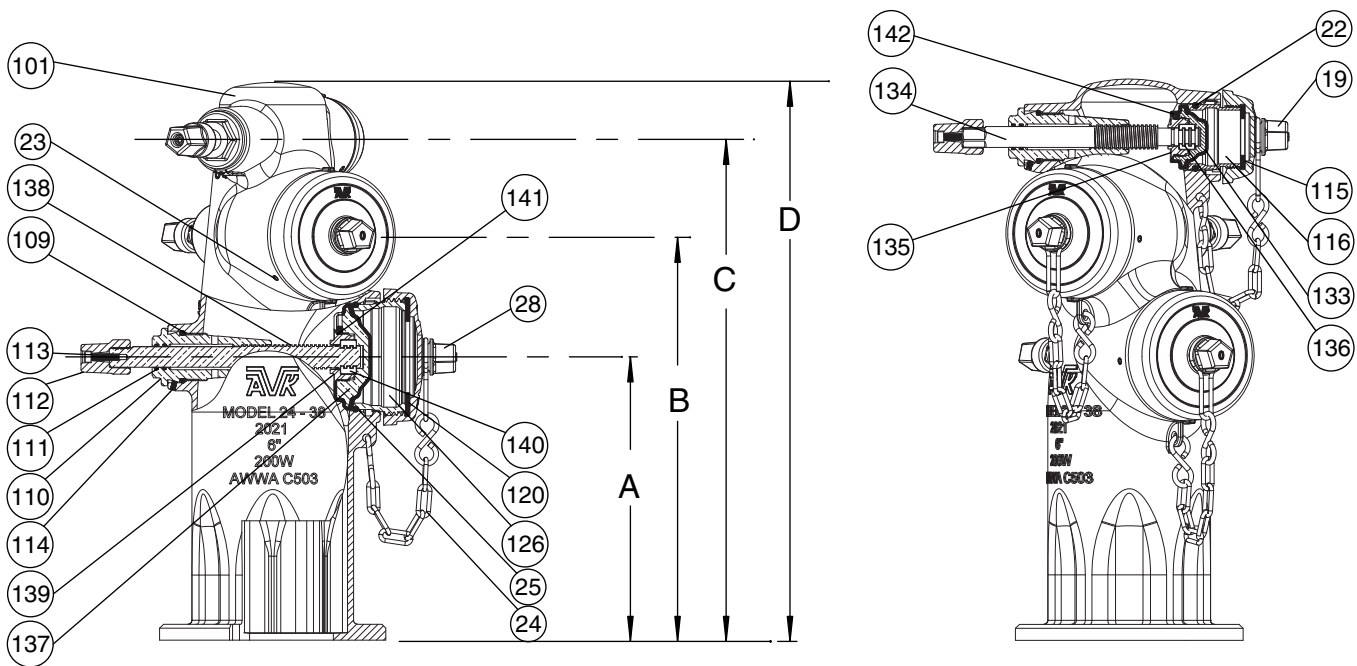

Ref No.	Outlets	A	B	C	D	Weights (lbs)
24S-PPH	2x2.5", 1x4"/4.5"	14"	18.75"	21.75"	25.00"	101

With optional factory assembled breakable unit, add 42 lbs. to shipping weight.

Note: 24S-PPH configurations supplied with 6 - 3/4" holes at 9 3/8" pitch diameter, to AWWA C503 specifications.

24S-PPH configurations supplied with 6 - 7/8" holes at 9 1/2" pitch diameter, to San Diego specifications.

24S-PPH configurations supplied with 8 - 7/8" holes at 9 1/2" pitch diameter, to ANSI B16.1-1975 class 125 specifications.

Breakable Flange Assemblies are available with the above bolting options.

