

AVK FULL PORT ECCENTRIC PLUG VALVE
250 PSI, Tested to AWWA C517
 Flanged Ends to ASME B16.1 Class 125 , Sizes 2½" - 12"

764/PV
FLxFL

Use:

For water and wastewater, to maximum 160°F.

Tests:

Hydraulic tests to AWWA C517:

Shell Test: 375 PSI
 Seat Test - direct pressure: 250 PSI
 Seat Test - reverse direction: 250 PSI

Standard Materials:

Body, Bonnet, ISO Flange	Ductile iron ASTM A536
Seat	Welded Nickel
Coating	Electrostatically applied fusion-bonded epoxy-resin Meets or exceeds AWWA C550
Plug Stems	Zinc plated Ductile Iron ASTM A536
Plug	Ductile iron ASTM A536 encapsulated with NBR
Bolting	Grade 8.8 Zinc Plated
Threaded Rod, Hex Nuts Washers	A-4 stainless steel
Bonnet Gasket, O-rings	ASTM D2000 Buna "N" nitrile rubber
Packing	V-type NBR

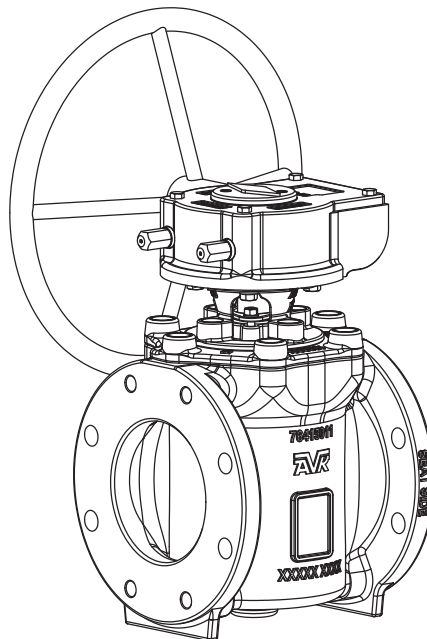

AVK FULL PORT ECCENTRIC PLUG VALVE
250 PSI, Tested to AWWA C517
Flanged Ends to ASME B16.1 Class 125 , Sizes 2½" - 12"

764/PV
FLxFL

Component List:

701. ISO Flange	705. Body	709. V-Pack	713. O-Ring
702. Bolts	706. Stud Bolt	710. Plug Core	714. Bearing
703. Bonnet	707. Hex Nut	711. Plug Rubber	715. Washer
704. Bonnet Gasket	708. Gland	712. Thrust Washer	730. Gearbox

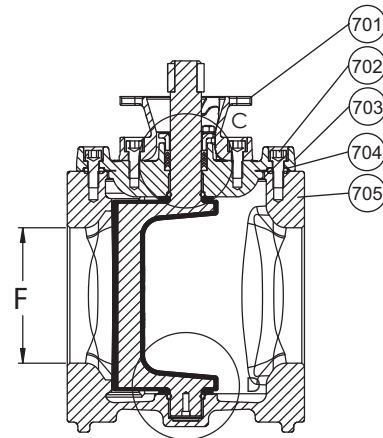
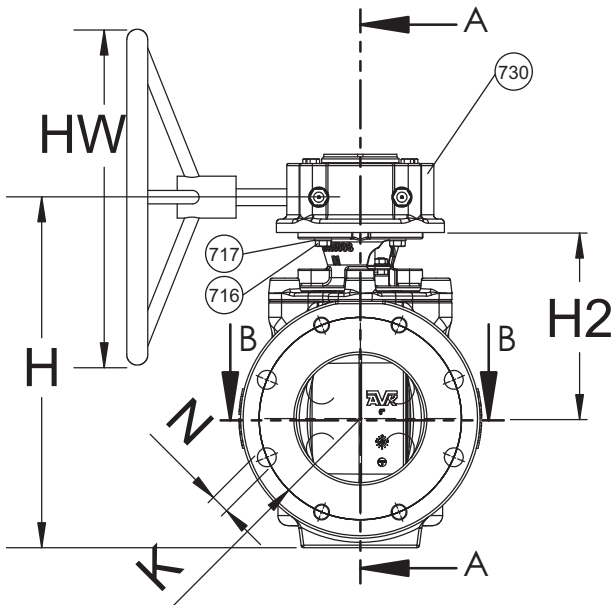

SECTION A-A

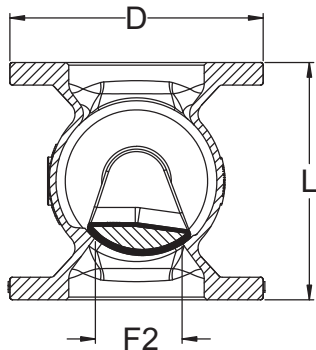

SECTION B-B

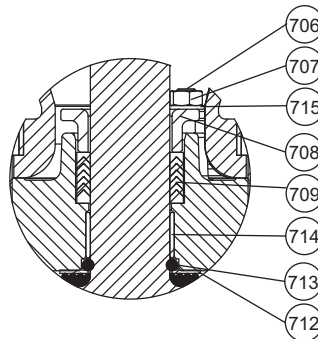

DETAIL C
SCALE 2 : 5

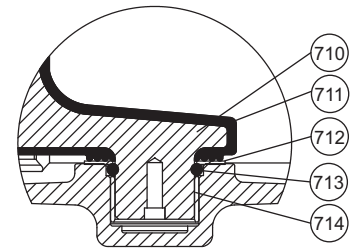

DETAIL D
SCALE 2 : 5

Ref No.	Size	D	F	F2	H	H2	HW	K	L	N	NO. OF HL/TH*	THREAD SIZE	SHPG. WT. LBS.
764-065-FF-GB	2.5"	7.09"	3.15"	1.46"	16.14"	6.65"	7.87"	5.51"	7.50"	0.75"	4/0	N/A	56
764-080-FF-GB	3"	7.87"	3.15"	2.24"	16.18"	6.69"	7.87"	5.98"	8.00"	0.75"	4/0	N/A	69
764-100-FF-GB	4"	9.06"	4.00"	2.72"	17.68"	7.48"	7.87"	7.51"	9.00"	0.75"	4/4	5/8-11 UNC	86
764-150-FF-GB	6"	11.22"	6.00"	3.78"	24.41"	8.82"	15.75"	9.50"	10.50"	0.88"	4/4	3/4-10 UNC	135
764-200-FF-GB	8"	13.58"	8.00"	4.21"	32.87"	12.17"	19.69"	11.77"	11.50"	0.88"	4/4	3/4-10 UNC	223
764-250-FF-GB	10"	15.94"	10.00"	5.31"	39.92"	14.45"	23.62"	14.25"	13.00"	1.00"	8/4	7/8-9 UNC	380
764-300-FF-GB	12"	19.09"	12.00"	5.98"	44.29"	16.50"	23.62"	17.00"	14.00"	1.00"	8/4	7/8-9 UNC	494

* HL/TH - Holes/Threaded per flange

